

USER'S GUIDE

WDXT-GEN Winchester Disk Controller

Important Information Do Not Discard

WD Feature Number	Feature Name	WD Feature Number
F000	Cache	F000
F001	Cache	F001
F002	Cache	F002
F003	Cache	F003
F004	Cache	F004
F005	Cache	F005
F006	Cache	F006
F007	Cache	F007
F008	Cache	F008
F009	Cache	F009
F010	Cache	F010
F011	Cache	F011
F012	Cache	F012
F013	Cache	F013
F014	Cache	F014
F015	Cache	F015
F016	Cache	F016
F017	Cache	F017
F018	Cache	F018
F019	Cache	F019
F020	Cache	F020
F021	Cache	F021
F022	Cache	F022
F023	Cache	F023
F024	Cache	F024
F025	Cache	F025
F026	Cache	F026
F027	Cache	F027
F028	Cache	F028
F029	Cache	F029
F030	Cache	F030
F031	Cache	F031
F032	Cache	F032
F033	Cache	F033
F034	Cache	F034
F035	Cache	F035
F036	Cache	F036
F037	Cache	F037
F038	Cache	F038
F039	Cache	F039
F040	Cache	F040
F041	Cache	F041
F042	Cache	F042
F043	Cache	F043
F044	Cache	F044
F045	Cache	F045
F046	Cache	F046
F047	Cache	F047
F048	Cache	F048
F049	Cache	F049
F050	Cache	F050
F051	Cache	F051
F052	Cache	F052
F053	Cache	F053
F054	Cache	F054
F055	Cache	F055
F056	Cache	F056
F057	Cache	F057
F058	Cache	F058
F059	Cache	F059
F060	Cache	F060
F061	Cache	F061
F062	Cache	F062
F063	Cache	F063
F064	Cache	F064
F065	Cache	F065
F066	Cache	F066
F067	Cache	F067
F068	Cache	F068
F069	Cache	F069
F070	Cache	F070
F071	Cache	F071
F072	Cache	F072
F073	Cache	F073
F074	Cache	F074
F075	Cache	F075
F076	Cache	F076
F077	Cache	F077
F078	Cache	F078
F079	Cache	F079
F080	Cache	F080
F081	Cache	F081
F082	Cache	F082
F083	Cache	F083
F084	Cache	F084
F085	Cache	F085
F086	Cache	F086
F087	Cache	F087
F088	Cache	F088
F089	Cache	F089
F090	Cache	F090
F091	Cache	F091
F092	Cache	F092
F093	Cache	F093
F094	Cache	F094
F095	Cache	F095
F096	Cache	F096
F097	Cache	F097
F098	Cache	F098
F099	Cache	F099
F100	Cache	F100

WESTERN DIGITAL

WD Feature Number	Feature Name	Capacity	Heads
F000	F000	21 MB	4
F001	F001	32 MB	5
F002	F002	32 MB	6
F003	F003	42 MB	8

The F000 allows:
 • dynamic low level formatting
 • virtual drive splitting
 • bad track formatting

INSTALL BOARD
 This section contains instructions for the physical installation to the controller board on IBM Personal Computer XT compatible Winchester disk controller. If the disk drives are being installed internally, locate the controller board in the closest available expansion slot next to the power supply. EXCEPT do not use the slot closest to the power supply in the IBM Personal Computer XT.

CAUTION
 Handle the controller board by the ends of the board. Some of the chips are static sensitive and damage may occur if the board is incorrectly handled.
WARNING! Turn off power before opening computer cover and installing controller board.

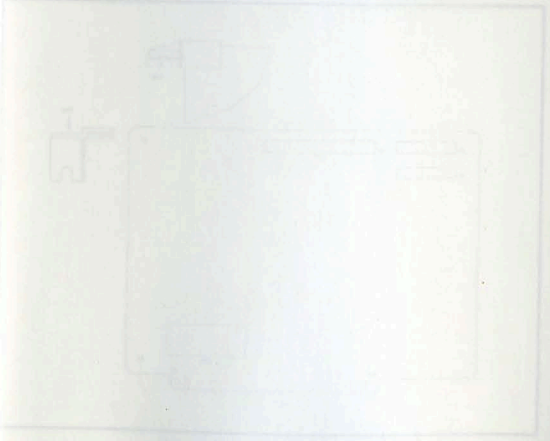

Figure 1. WDXT-GEN Connector, ROM Location, and Cap

INTRODUCTION

The installation of the WDXT-GEN controller consists of:

- physically installing the XT-GEN controller board
- formatting the disk drives

The WDXT-GEN controller is an easy to install, primary controller. There are no confusing jumpers for you to set. You simply order the feature number which corresponds to the drive you wish to install.

Table 1 Feature Number vs. Disk Drives lists several major disk drive manufacturers and the model numbers that correspond to each Western Digital feature. Just look in the table, locate your disk drive, then order the corresponding Western Digital feature number.

Table 1 Feature Number vs. Disk Drives

WD Feature Number	Drive Manufacturer	Drive Model Number
F300*/F320	Alps	DRN020A
		DRM020A
	CMI	3426
		PT925
	Cognito	FK302-26
		LX200
	Fuji	LX2000
		HH325
	Microscience	HH625
		HH725
		3425
	Miniscribe	7426
		8425
		MR522
	Mitsubishi	5126
		OD526
	NEC	HD662/12
		RO365
	Okidata	ST125
		ST138
Olivetti	ST225	
	SQ325F	
Rodime	SQ325AF	
	TM262	
Seagate	TM362	
	TM702	
Syquest	Tandon	WRENII
		9415-5-38
F335	CDC	3530
		ST4038
F336	Citoh	6640
		Seagate
F340	CMI	RO203E
		Rodime
F340	Micropolis	SQ340AF
		Seagate
F340	Tulin	T240
		1304
F340	Seagate	ST251

Table 2 WDXT-GEN Feature Number Characteristics

WD Feature Number	Formatted Capacity	Heads	Number of Cylinders	Pre-Comp RWC	Step Rate
F300*/F320	21 MB	4	615	307 none	30 microsecond
F335	32 MB	5	733	367 none	18 microsecond
F336	32 MB	6	640	210 210	18 microsecond
F340	42 MB	6	820	410 none	18 microsecond

*The F300 allows:

- dynamic low level formatting
- virtual drive splitting
- bad track formatting

INSTALL BOARD

This section contains instructions for the physical installation of the controller board, an IBM Personal Computer XT-compatible Winchester disk controller. If the disk drives are being installed internally, locate the controller board in the closest available expansion slot next to the power supply, EXCEPT do not use the slot closest to the power supply in the IBM Personal Computer XT.

CAUTION

Handle the controller board by the ends of the board. Some of the chips are static sensitive and damage may occur if the board is incorrectly handled.

WARNING!! Turn off power before opening computer cover and installing controller board.

Figure 1 shows the connector locations (J1, J2, and J3) on the XT-GEN board and the location of the BIOS ROM (U13).

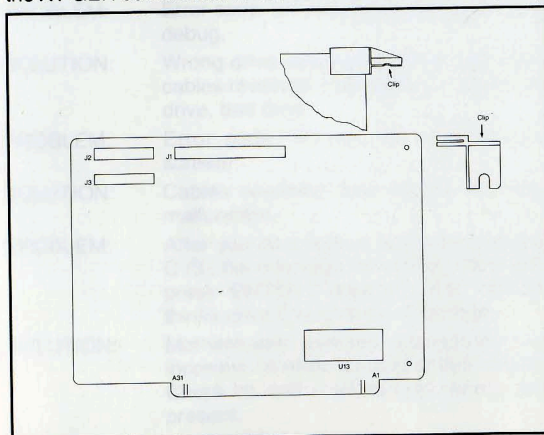

Figure 1. WDXT-GEN Connectors, BIOS Location, and Clip

Install clip on board as shown in Figure 2. Figure 2 contains a summary of the board installation steps.

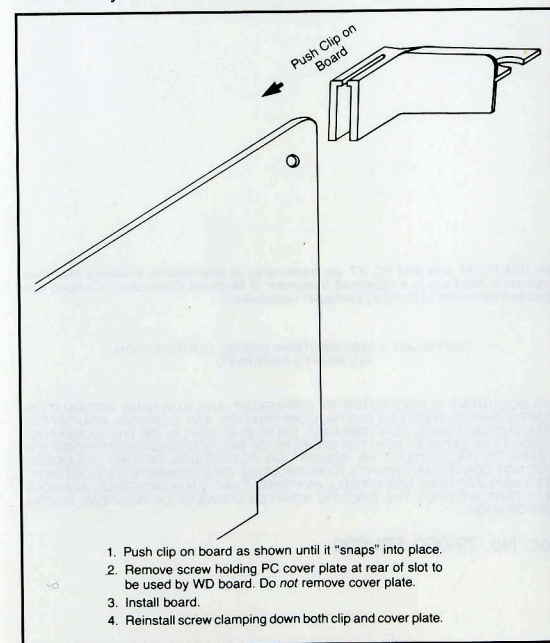

Figure 2. WDXT-GEN Board Installation Summary

Next, using a screwdriver, loosen the screw holding the expansion slot bracket. Remove the screw, but keep the bracket in place. Save the screw to hold the new controller board and the bracket.

Connect the 34-pin (wide control cable) connector to J1 on the controller board. Check that Pin 1 of the cable connector

goes to Pin 1 on the controller board. Pin 1 of the cable connector is typically located on the color coded side of the cable.

Connect the 20-pin (data cable) to J2 (Drive 0 Data Connector) on the controller board. Check that Pin 1 on the cable is connected to Pin 1 on the controller board.

If a second drive is being installed, connect the other 20-pin (data cable) to J3 (Drive 1 Data Connector) on the controller board.

Verify that the disk drives are properly installed. Check the drive select jumpers and drive termination resistors. See the disk drive installation manual for further information.

DO NOT USE THE RADIAL SELECT OPTION.

To install the controller board, press and insert the board into the expansion slot. Check that the board is seated properly by pressing down firmly on both ends of the board.

After the board is seated firmly in the socket, secure the board and clip with the bracket screw that you removed earlier.

CAUTION

When routing cables, be careful not to pinch them. Cables must not get caught between the cover and the boards, nor should they obstruct any air flow path from fans or vents.

FORMAT INSTRUCTIONS

The format instructions that you follow are simple procedures to tell the computer that you have either one or two Winchester disk drives installed.

Run Debug Utility

The DEBUG Utility supplied with DOS initiates the controller format program and physically formats the drive. While you are running the controller format program, prompts request you to answer questions that describe your system. See your DOS manual for detailed instructions on how to run the debug utility.

Format Notes

1. Debug is usually located on the Supplemental Disk.
2. For IBM systems only — at the debug prompt, verify that the BIOS is 10-27-82 or later by doing the following:

Type: **d f000:fff5 fffc**
Press **CR**

3. Remember, if any key other than Y is typed when initiating the controller format program, the program displays the following message and returns you to DOS.

Nothing done exit

4. Should the system detect an error during formatting, the program terminates, returns to the operating system, and displays the following error message:

Error...completion code xx

See Table 3 for a list of error codes.

Table 3 Error Codes

Codes	Completion Code Summary
01	Bad Command
02	Address Mark Not Found
04	Sector Not Found
05	Reset Failed
07	Set Parameters Failed
09	Attempt to DMA Across 64K Boundary
0B	Bad Track
10	Uncorrectable Data Error
11	ECC Error Corrected
20	Controller Failure
40	Seek Failure
80	Time-out
BB	Undefined Error
FF	Read Status Failed

Format Step Instructions

1. At the A> prompt, load and run the DOS debug utility.

Type: **DEBUG**
Press **CR**

2. At the debug prompt (-),

Type: **g=c800:5**
Press **CR**

The controller format program displays one of the following messages:

2A.

WX2 Format Revision 7.0 © Copyright Western Digital Corp. 1985
(AH) = Relative drive number (0-7)
(AL) = Interleave factor (3 standard)
Press Y to begin formatting drive C with interleave 03

If you have message 2A, go to step 3.

2B.

XT-GEN Dynamic Formatter Rev. 1.0
© Copyright Western Digital Corp. 1987 Current Drive is C:
Select new Drive or RETURN for current

If you have message 2B, go to step 5.

CAUTION

Remember that all existing data on the target drive is lost during formatting. Back up your data before continuing. To abort the format, hit any other key except Y.

3. To start the format for drive C with interleave 3,

Type: **Y**

When the format is completed, the following is displayed:

Format Successful
A>

If you have a second drive to format or wish to change the interleave factor, go to step 3A. Otherwise, skip to step 4.

- 3A. To format a second drive, or change the interleave factor, you must return to the debug utility (step 1). At the debug prompt (-),

Type: **rax**
Press **CR**

The debug program displays the following:

AX: 0000
:

At the colon (:) prompt, enter the drive number and interleave factor followed by a RETURN.

xxyy

where: xx = relative drive number
yy = interleave factor

For drive C xx = 00 and drive D xx = 01

For interleave factor 3 yy = 03

The interleave factor is system dependent. While an interleave factor of 3 is standard, 3 may not be the best interleave factor for your system. You can determine the interleave factor through experimentation; however, if you don't know your optimum interleave factor, start with an interleave factor of 3.

To set drive D with an interleave factor of 3

Type: **0103**
Press **CR**

This sets the interleave factor at 3 for drive D.

At the debug prompt (-),

Type: **g=c800:5**
Press **CR**

The controller format program displays the following:

WX2 Format Revision 7.0 © Copyright Western Digital Corp. 1985
(AH) = Relative drive number (0-7)
(AL) = Interleave factor (3 standard)
Press Y to begin formatting drive D with interleave 03

Type: **Y**

When the format is completed, the following displays:

Format Successful
A>

This completes your formatting.

After you see this message, go to step 4.

4. Load and execute the FDISK and FORMAT utilities. See your DOS manual for details.

After you complete step 4, this completes your installation. Do not go to step 5, unless you have message 2B.

5. Enter your choice of drives at this point. The program continues.

Curent Interleave is 3
Select new Interleave or RETURN for current.

Enter your choice of interleave at this point. The program continues. The next displayed message is:

**Are you dynamically configuring the drive —
answer Y/N**

Enter "N" if you are NOT dynamically configuring the drive. The program displays the initiate format message. Continue from that point.

Enter "Y" if you ARE dynamically configuring the drive. The program displays the initiate dynamic configuration message:

**Key in disk characteristics as follows:
ccc h rrr ppp ee o where**

- ccc = total number of cylinders (1–4 digits)**
- h = number of heads (1–2 digits)**
- rrr = starting reduced write current cylinder (1–4 digits)**
- ppp = write precomp cylinder (1–4 digits)**
- ee = max correctable error burst length (1–2 digits) range = 5 to 11 bits, default = 11 bits**
- o = CBB option byte, step rate select (1 hex digit) range = 0 to 7, default = 5 refer to controller and drive specification for step rates**

Enter each value separated by a space and follow the complete entry with a RETURN. Enter physical cylinder values. Refer to Table 4 for step rates and the step rate codes.

EXAMPLE FOR ST 225:

615 4 616 616 11 5 CR

Program displays:

**Are you virtually configuring the
drive — answer Y/N**

Enter "N" if no virtual configuration. Program displays initiate format message. Repeat this low level format procedure for a second physical drive (if present) after successfully formatting physical drive C:.

Current versions of DOS allow no more than 32 megabytes per drive. Therefore, a 40 megabyte drive may be divided into two virtual drives using the virtual option. Figure 3 provides an example of how to calculate total drive capacity and establish virtual parameters.

Enter "Y" for virtual configuration. Do not attach another physical drive to the controller or add another Winchester controller to the system when using virtual configuration. Also, do NOT repeat this low level format procedure for logical drive D:.

The program continues with the following display:

**Key in cylinder number for drive split as vvv...
where vvv = number of cylinders for drive C:
(1–4 digits)**

Enter the ending cylinder number for drive C:. Drive D: uses the remaining cylinders. Figure 3 illustrates how to calculate a virtual split.

The capacity of a drive can be easily calculated as follows:

$$\text{Capacity} = (\# \text{Cyl.})(\# \text{Heads})(\# \text{Sectors/Tracks})$$

(Sector Size in Bytes)

If a drive has 612 cylinders, 8 heads, 17 sectors per track and a 512 byte sector size, then calculate the logical split as follows:

$$\text{Total capacity} = 42,614,784 \text{ bytes}$$

$$\text{or } (612)(8)(17)(512)$$

To split the drive into 2 logical drives of 30 and 10 megabytes each of X and Y respectively, do the following calculations.

Because (X)(heads)(sectors/track) (sector size) = 30 megabytes.

Note: 1 megabyte = 2^{20} bytes = 1,048,576 bytes.

$$X = (31,457,280)/(8)(17)(512)$$

$$X = 451.8 = 451 \text{ cylinders}$$

Note: Round X down to the nearest whole number.

Since Y = Total capacity - X

$$Y = 612 - 451 \text{ or } 161$$

$$\text{The split} = 451 \text{ } 161$$

Figure 3. Logical Format Calculation

EXAMPLE FOR ST 225:

315 CR

The program displays the initiate format message:

**Press "Y" to begin formatting drive (C or D) with
interleave (03 or value entered above)**

If any key other than "Y" is typed, the program displays the following message and returns the operator to DOS.

**Nothing done exit —
returning to system...**

A>

If an error occurs while formatting, the program immediately terminates, displays the following error message, and returns the operator to DOS. XX is the hexadecimal BIOS completion code defined in Table 3

Error — — — completion code XX

A>

If "Y" is typed, the program initiates the low level format. The following message indicates that the controller is formatting the drive:

Formatting...

The screen displays the following message if there are no resulting errors:

Do you want to format bad tracks — answer Y/N

The user is prompted to enter, via keyboard, a bad track list if "Y" is pressed. This list should be provided by the drive manufacturer.

Because of the logical addressing used by DOS, marking an entire track bad will result in more than one logical address being marked bad. As DOS can only accept a limited number of defects, a drive with excessive media defects may cause the FORMAT program to terminate with an error. The displayed error is typically, "TRACK 00 BAD — DRIVE UNUSABLE."

Pressing "Y" causes the program to display the following message:

Key in bad track list as follows:

ccc h ...where

ccc = bad track cylinder no (1-4 digits)

h = bad track head number (1-2 digits)

Table 4 Stepping Rate Codes

Code	Rate
0	3 msec. per step
1	45 μ sec. per step
2	60 μ sec. per step
3	18 μ sec. per step
4	210 μ sec. per step
5	75 μ sec. per step
6	30 μ sec. per step
7	18 μ sec. per step

Type in the cylinder and head numbers for the bad tracks, separate the cylinder and head numbers with a space, and follow with a RETURN.

EXAMPLE:

160 1 161 2 304 3 223 4 223 2 CR

The program continues.

More? Y/N

Enter the extra bad track. Terminate bad tracking formatting by typing:

N CR

The program continues.

BAD TRACK MAP

TRACK ADDR
ccc h

PROBLEM
USER-SUPPLIED

If no errors occurred, the program ends execution of the low level format with the Format Successful message.

Format Successful

System will now restart

Insert DOS diskette in drive A:

Press any key when ready.

- Repeat Step 1, 2, 2B and 5 if a second physical drive is to be formatted. Do NOT virtually configure the second physical drive. Do NOT run the low level format on the second logical drive if drive C: was virtually configured.

- Load and execute the DOS FDISK utility for both drives regardless of virtual or physical configuration. FDISK partition data should indicate the proper split of cylinders for both drives.
- Load and execute the DOS FORMAT utility for both drives regardless of virtual or physical configurations.

If You Have A Problem

First check your physical installation. Check for reversed cables, an overloaded system power supply, incorrect drive selection, etc.

This section lists some common problems and possible solutions when installing the controller.

PROBLEM: Winchester activity LED always lit.

SOLUTION: Cables reversed, drive malfunction, or bad cables.

PROBLEM: "Nothing done exit" appears when starting the low level-format program.

SOLUTION: Did not press "Y." Restart at step 1 of format instructions.

PROBLEM: System hangs with controller installed.

SOLUTION: System BIOS may not handle Winchester disk. Update system BIOS.

PROBLEM: "Error Reading Fixed Disk" when booting the system.

SOLUTION: DOS partition not active. See FDISK instructions in your DOS manual.

PROBLEM: "Hard Disk Drive Not Ready" or "01" Error Code.

SOLUTION: System BIOS does not support Winchester controller and drive. Overloaded power supply. Update system BIOS.

PROBLEM: Error code "80" when formatting through debug.

SOLUTION: Wrong drive select jumped on hard disk; cables reversed, bad cables, no power to drive, bad drive.

PROBLEM: Error code "40" or "20" appears on screen.

SOLUTION: Cables reversed, bad cables, or drive malfunction.

PROBLEM: After you do a high level format (Format C:/S), the message "Insert disk drive and press ENTER." appears. The system thinks drive C is a floppy disk drive.

SOLUTION: Motherboard switches are set for the incorrect number of floppy disk drives. Check to see if RAM disk drivers are present.

PROBLEM: "Bad Track 0" using DOS 3.1.

SOLUTION: Make a config.sys file with BUFFERS=99. Reboot to load the configuration.

PROBLEM: "Bad Track 0" using DOS 2.1 (DOS 2.1 cannot support bad tracks above 16.7 MB.)

SOLUTION: Upgrade system to DOS 3.1.

If you require further information or other technical support, please contact your authorized dealer:

IBM, IBM PC AT and IBM PC XT are trademarks of International Business Machines Corporation. MS-DOS is a registered trademark of Microsoft Corporation. Compaq is a registered trademark of Compaq Computer Corporation.

COPYRIGHT © 1987 WESTERN DIGITAL CORPORATION
ALL RIGHTS RESERVED

THIS DOCUMENT IS PROTECTED BY COPYRIGHT, AND CONTAINS INFORMATION PROPRIETARY TO WESTERN DIGITAL CORPORATION. ANY COPYING, ADAPTATION, DISTRIBUTION, PUBLIC PERFORMANCE, OR PUBLIC DISPLAY OF THIS DOCUMENT WITHOUT THE EXPRESS WRITTEN CONSENT OF WESTERN DIGITAL CORPORATION IS STRICTLY PROHIBITED. THE RECEIPT OR POSSESSION OF THIS DOCUMENT DOES NOT CONVEY ANY RIGHTS TO REPRODUCE OR DISTRIBUTE ITS CONTENTS, OR TO MANUFACTURE, USE OR SELL ANYTHING THAT IT MAY DESCRIBE, IN WHOLE OR IN PART, WITHOUT THE SPECIFIC WRITTEN CONSENT OF WESTERN DIGITAL CORPORATION.

Doc. No. 79-000-173-000

Western Digital
2445 McCabe Way
Irvine, California 92714
(800) 847-6181

W1441S 9/8 100M