HP OmniBook 4100



Service Manual

Notice

In a continuing effort to improve the quality of our products, technical and environmental information in this document is subject to change without notice.

This manual and any examples contained herein are provided “as is” and are subject to change without notice. Hewlett-Packard Company makes no warranty of any kind with regard to this manual, including, but not limited to, the implied warranties of merchantability and fitness for a particular purpose. Hewlett-Packard Co. shall not be liable for any errors or for incidental or consequential damages in connection with the furnishing, performance, or use of this manual or the examples herein.

Consumer transactions in Australia and the United Kingdom: The above disclaimers and limitations shall not apply to Consumer transactions in Australia and the United Kingdom and shall not affect the statutory rights of Consumers.

© Copyright Hewlett-Packard Company 1998. All rights reserved. Reproduction, adaptation, or translation of this manual is prohibited without prior written permission of Hewlett-Packard Company, except as allowed under the copyright laws.

The programs that control this product are copyrighted and all rights are reserved. Reproduction, adaptation, or translation of those programs without prior written permission of Hewlett-Packard Co. is also prohibited.

Portions of the programs that control this product may also be copyrighted by Microsoft Corporation, SystemSoft Corp., Crystal Semiconductor Corporation, Phoenix Technologies, Ltd., and NeoMagic, Inc. See the individual programs for additional copyright notices.

Microsoft, MS, MS-DOS, and Windows are registered trademarks of Microsoft Corporation. Pentium and the Intel Inside logo are U.S. registered trademarks and MMX is a U.S. trademark of Intel Corporation. TrackPoint is a U.S. registered trademark of International Business Machines.

All certifications may not be completed at product introduction. Check with your HP reseller for certification status.

This equipment is subject to FCC rules. It will comply with the appropriate FCC rules before final delivery to the buyer.

Hewlett-Packard Company
Mobile Computing Division
19310 Pruneridge Ave.
Cupertino, CA 95014, U.S.A.

Edition History

Edition 1.....April 1998

Contents

1. Product Information	1-1
Features and Operation.....	1-2
Turning the OmniBook On and Off	1-4
Checking the Status of the OmniBook	1-4
Using Fn Hot Keys	1-6
Resetting the OmniBook	1-6
System Resources	1-7
Specifications	1-9
Internal Design	1-12
2. Removal and Replacement	2-1
Removing the Battery or Plug-In Module (User-Replaceable)	2-3
Removing a RAM Board (User-Replaceable).....	2-4
Removing the Hard Disk Drive (User-Replaceable).....	2-5
Replacing Small Parts (User-Replaceable)	2-7
Removing the Keyboard (HP Authorized Service Providers Only).....	2-8
Removing the Display Assembly (HP Authorized Service Providers Only)	2-10
Removing the LCD Module (HP Authorized Service Providers Only)	2-11
Removing the Top Case (HP Authorized Service Providers Only)	2-14
Removing the Motherboard or Bottom Case (HP Authorized Service Providers Only).....	2-16
Removing the BIOS IC (HP Authorized Service Providers Only)	2-19
Removing Other Components (HP Authorized Service Providers Only)	2-21
3. Troubleshooting and Diagnostics	3-1
Troubleshooting	3-2
Troubleshooting the Problem	3-2
Verifying the Repair	3-3
Suggestions for Troubleshooting.....	3-4
Diagnostic Tools	3-12
OmniBook Diagnostic Program	3-12
Power-On Self-Test	3-17
Sycard PCCTest 450 CardBus Card (Optional)	3-20
Desktop Management Interface (DMI)	3-21
BIOS Setup Utility.....	3-23
4. Replaceable Parts	4-1
5. Reference Information	5-1
Password Removal Policy	5-1
Hewlett-Packard Display Quality Statement.....	5-2

Figures

Figure 1-1. OmniBook - Front View.....	1-2
Figure 1-2. OmniBook - Side View	1-2
Figure 1-3. OmniBook - Rear View.....	1-3
Figure 1-4. Replaceable Module Diagram.....	1-12
Figure 2-1. Removing the Battery or Plug-In Module	2-3
Figure 2-2. Removing a RAM Board.....	2-4
Figure 2-3. Removing the Hard Disk Drive.....	2-5
Figure 2-4. Installing a Hard Drive in the Cover	2-6
Figure 2-5. Removing the Keyboard.....	2-8
Figure 2-6. Removing the Display	2-10
Figure 2-7. Removing the Display	2-13
Figure 2-8. Removing the Top Case	2-15
Figure 2-9. Removing the Motherboard.....	2-17
Figure 2-10. Installing Docking Doors and Module Latch	2-19
Figure 2-11. Positioning Thermal Pads.....	2-19
Figure 2-12. Removing the BIOS IC	2-20
Figure 3-1. Basic Troubleshooting Steps.....	3-2
Figure 3-2. OmniBook Diagnostic Screens — Basic and Advanced.....	3-12
Figure 3-3. Serial and Parallel Loopback Connectors.....	3-14
Figure 3-4. DMI Components.....	3-22
Figure 4-1. Exploded View	4-2
Figure 4-2. Display Components	4-5
Figure 4-3. Motherboard Components.....	4-6

Tables

Table 1-1. OmniBook 4100 Models	1-1
Table 1-2. Product Comparisons.....	1-3
Table 1-3. Activating Power Modes	1-4
Table 1-4. Main Status Lights (LED Strip Cable)	1-5
Table 1-5. Keyboard Status Lights (VGA PCA)	1-5
Table 1-6. Fn Hot Keys.....	1-6
Table 1-7. System Interrupts	1-7
Table 1-8. System Memory	1-7
Table 1-9. System Input/Output Addresses (100-3FF)	1-8
Table 1-10. DMA Channels.....	1-8
Table 1-11. OmniBook 4100 Specifications.....	1-9
Table 1-12. OmniBook 4100 Accessories	1-11
Table 1-13. Functional Structure.....	1-13
Table 2-1. Removal Cross-Reference	2-1
Table 2-2. Required Equipment	2-2
Table 2-3. Recommended Screw Torques	2-2
Table 2-4. RAM Board Replacement Part Numbers	2-4
Table 2-5. Hard Disk Drive Replacement Part Numbers.....	2-5
Table 2-6. Replacing Small Parts (User-Replaceable).....	2-7
Table 2-7. Display Component Compatibility	2-11
Table 2-8. Removing Display Components	2-21
Table 2-9. Removing Top Case Components	2-23
Table 2-10. Removing Bottom Case Components.....	2-23
Table 3-1. Scope of Diagnostic Tools.....	3-4

Table 3-2. Troubleshooting Suggestions.....	3-5
Table 3-3. OmniBook Diagnostic Error Codes.....	3-14
Table 3-4. POST Terminal-Error Beep Codes.....	3-17
Table 3-5. POST Messages.....	3-18
Table 3-6. BIOS Setup Menus and Parameters.....	3-23
Table 4-1. OmniBook Replaceable Parts.....	4-3
Table 4-2. Assembly-Component Breakdown.....	4-7
Table 4-3. Accessory Replaceable Parts.....	4-7
Table 4-4. Part Number Reference.....	4-8
Table 5-1. OmniBook 4100 LCD Guidelines (TFT).....	5-3

Introduction

This service manual provides reference information for the HP OmniBook 4100. It is intended to be used by HP-authorized service personnel in the installation, servicing, and repair of these products.

The manual is designed as a self-paced guide. It is intended to train you to install, configure, and repair OmniBook computers. You can follow this manual without having equipment available.

The following table lists additional places where you can get supplementary information about OmniBook products.

Sources of OmniBook Information

Source	Address or Number	Comments
HP External Web	http://www.hp.com/go/omnibook (http://www2.hp.com/go/omnibook , European mirror)	No usage restriction.
HP US Reseller Web	http://partner.americas.hp.com	Restricted to Authorized Resellers only.
HP Asia Pacific Channel Support Centre for DPSP Partners	http://www.hp.com.au	Restricted to DPSP Partners only.
America Online	Keyword: HP	Call (800) 827-6364 for membership within the US.
CompuServe*	GO HP	Call (800) 524-3388 for membership within the US.
HP Bulletin Board Service		Refer to the latest Product Support Plan for non-US BBS numbers.
HP First (automated fax)	(800) 333-1917	US and Canada.
	(801) 344-4809	Outside US and Canada.
	(800) 544-9976	Reseller support number (enter outlet id number).
HP Support Assist CD-ROM	(800) 457-1762	US and Canada.
	(801) 431-1587	Outside US and Canada.
* Baud rates = 300-28,800; Parity = E; Data bits = 7; Stop bits = 1.		

Product Information

The HP OmniBook 4100 provides desktop performance and expandability as well as convenient portability. It uses high-performance component technologies that make it capable of replacing a desktop computer or serving as a portable multimedia presentation tool.

Table 1-1. OmniBook 4100 Models

OmniBook Product *	CPU **	Display	Hard Drive	Floppy Drive	CD-ROM Drive	Standard RAM
F1462N F1462W	Pentium II 233 MHz	13.3-inch XGA TFT	4.0 GB (F1467A)	1.44 MB (F1472A)	CD-ROM (F1474A)	32 MB
F1463N F1463W	Pentium 266 MHz	14.1-inch XGA TFT				
F1464N F1464W	Pentium II 266 MHz		6.4 GB (F1475A)			
F1479N F1479W F1479WT			4.0 GB (F1467A)			
<p>* For the products listed: "N" suffix means Windows NT 4.0 Workstation installed. "W" or "WT" suffix means Windows 95 installed.</p> <p>** Intel Mobile Pentium or Pentium II processor.</p>						

This chapter describes

- Features and operation (below).
- Specifications (page 1-9).
- Internal design (page 1-12).

Features and Operation

The following three illustrations point out the main external features of the computer. They are followed by highlights of the computer's operation. For an internal, exploded view, see page 4-2.

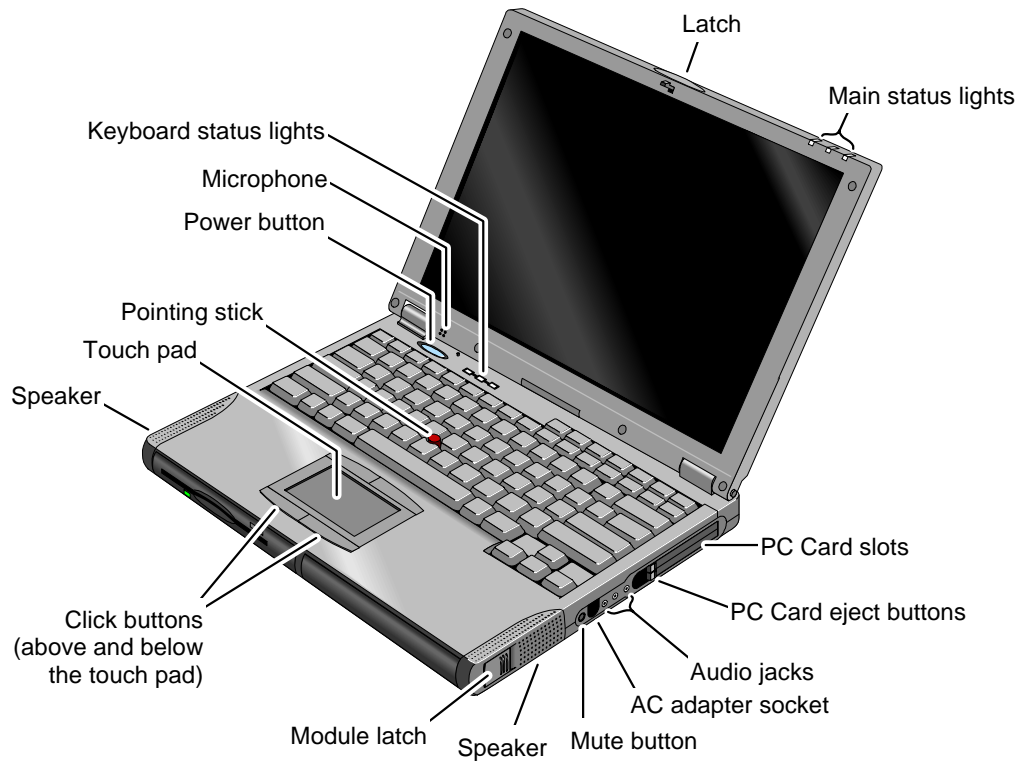

Figure 1-1. OmniBook - Front View

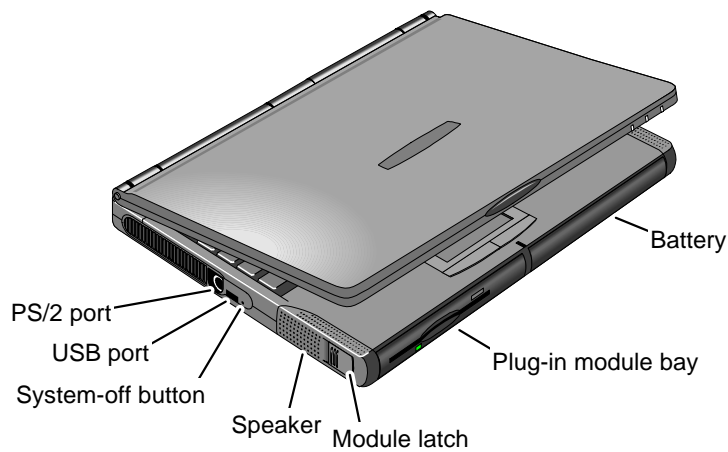

Figure 1-2. OmniBook - Side View

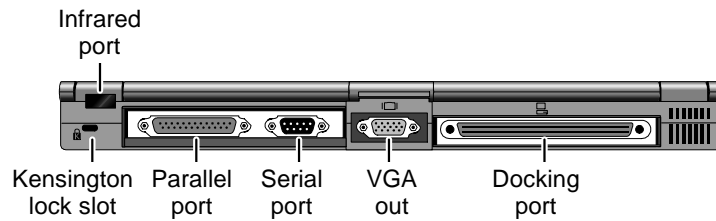

Figure 1-3. OmniBook - Rear View

Table 1-2. Product Comparisons

	OmniBook 7100	OmniBook 4100	OmniBook 2100/3100	OmniBook 3000
Processor *	Intel Pentium II (266 MHz), with MMX technology. 512-KB burst-synchronous L2 cache (high-speed bus).	Intel Pentium II (266 or 233 MHz), or Pentium (266 MHz), with MMX technology. 512-KB burst-synchronous L2 cache (high-speed bus for Pentium II).	Intel Pentium (266, 233, or 200 MHz), with MMX technology. 512-KB burst-synchronous L2 cache.	Intel Pentium (266, 233, or 200 MHz), with MMX technology. 512-KB burst-synchronous L2 cache.
Memory	32 MB RAM on motherboard. Expandable to 160 MB.	32 MB RAM on motherboard. Expandable to 96 MB.	32 MB RAM on motherboard. Expandable to 96 MB.	16 MB RAM on motherboard. Expandable to 144 MB.
Display	14.1-inch TFT XGA display.	14.1- or 13.3-inch TFT XGA display.	13.3-inch TFT XGA display, or 12.1-inch TFT or DSTN SVGA display.	13.3-inch TFT XGA display.
Video	PCI local bus video. 64-bit graphics controller with 4 MB external video RAM. Up to 16M colors (XGA). Zoomed Video enabled.	PCI local bus video. 128-bit graphics controller with 2 MB internal video RAM. Up to 64K colors (XGA). Zoomed Video enabled.	PCI local bus video. 128-bit graphics controller with 2 MB internal video RAM. Up to 64K colors (XGA), 16M colors (SVGA). Zoomed Video enabled.	PCI local bus video. 128-bit graphics controller with 2 MB internal video RAM. Up to 64K colors (XGA). Zoomed Video enabled.
Operating System	Windows 95 or Windows NT 4.0 preinstalled.	Windows 95 or Windows NT 4.0 preinstalled.	Windows 95 or Windows NT 4.0 preinstalled.	Windows 95 preinstalled. (Windows NT 4.0 certified.)
Desktop Management Interface	DMI 2.0. HP TopTools 2.6.	DMI 2.0. HP TopTools 2.6.	DMI 2.0. HP TopTools 2.6.	DMI 1.1. HP TopTools 2.0.
Power Management	APM 1.2. ACPI compliant.	APM 1.2. ACPI compliant.	APM 1.2. ACPI compliant.	APM 1.2.
Power States	On, Standby, Suspend, Hibernate, Off.	On, Standby, Suspend, Hibernate, Off.	On, Standby, Suspend, Hibernate, Off.	On, Standby, Suspend, Hibernate, Off.
Features at the time of product introduction. Not updated for later versions.				
* Intel Mobile Pentium or Mobile Pentium II processor.				

Turning the OmniBook On and Off

- **On.** Press the blue power button to turn on the OmniBook.
- **Standby.** The display turns off automatically if the computer is inactive for about 2 minutes.
- **Suspend.** Click Start, Suspend (Windows 95) or press the blue power button briefly (about 1 second) to suspend activity when the OmniBook is on. When you turn on the computer, it resumes your previous work session.

Closing the lid (for more than 2 seconds) also suspends the computer.

- **Hibernate.** Press Fn+F12. This is like Off, except that your current work session is first saved to disk. When you turn on the computer, it reboots and restores your previous session.
- **Off.** Click Start, Shut Down. If the OmniBook does not respond, press and hold the blue power button until the display shuts down. When you turn on the computer, it reboots. Unsaved data is lost.













Table 1-3. Activating Power Modes

Power Mode	To Enter Mode	To Turn Back On
Standby Reduced-power/stopped state. Display is off. Everything is in a reduced-power state. Network devices are maintained. Your current work session continues at turn-on (any key or pointer action).	Press Fn+S –or– allow time-out.	Press any key or move a pointing device to display the current session ("Instant-On").
Suspend Low-power/stopped state. Lower power state than Standby. Everything is off or in a low-power state. Network devices are off. Your previous work session resumes at turn-on. For plug-and-play operating systems, network connections resume at turn-on.	Press blue power button for about 1 second –or– close the lid* –or– click Start, Suspend (Windows 95) –or– allow time-out.	Press blue power button to display the current session ("Instant-On").
Hibernate No-power/stopped state. Session is saved on the hard disk. Everything is shut down. Computer reboots at turn-on and restores previous session and network connections (if plug-and-play).	Press Fn+F12 –or– allow time-out.	Press blue power button to restart and restore the previous session.
Off No-power/stopped state. Everything is shut down (battery continues charging if ac adapter is connected). Computer reboots at turn-on and restores network connections.	Click Start, Shut Down –or– Press and hold the blue power button until the display shuts down.	Press blue power button to restart with a new session.
* Does not suspend if Video Display Device set to Both in BIOS Setup.		

Checking the Status of the OmniBook













The main OmniBook status lights, located at the front-right edge of the display bezel at the top of the display, indicate power status and drive activity. (These lights are on the LED strip cable.)

Table 1-4. Main Status Lights (LED Strip Cable)

  	Meaning
  	Power mode Steady green light: OmniBook is running (On mode). Steady orange light: OmniBook is suspended (Suspend or Standby mode). No light: OmniBook is off (Off or Hibernate mode). Alternating green and orange light: OmniBook failed when resuming.
  	Hard disk drive Green light: OmniBook is accessing the hard disk drive (no other drive).
  	Charging Steady green light: AC adapter is connected, battery is full. Blinking green light: AC adapter is connected, battery is charging. No light: AC adapter is not connected.

The keyboard status lights, located above the keyboard, indicate the states of the keyboard locks. (These lights are on the VGA PCA.)

Table 1-5. Keyboard Status Lights (VGA PCA)

  	Meaning
  	Caps Lock Caps Lock is active.
  	Keypad Lock The embedded keypad is active (Fn+F8). Num Lock must also be on for the numeric keys—otherwise, cursor control is active.
  	Num Lock Num Lock is active.

In addition, the battery module has five lights that indicate its charge level. To view the lights, you have to remove the battery and press the pad on the back next to the connector. The number of lights that turn on indicates the charge.

Using Fn Hot Keys

The Fn key combined with another key is a hot key—a shortcut key sequence for various system controls. For an external keyboard, CTRL+ALT is normally equivalent to the Fn key.

Table 1-6. Fn Hot Keys

Hot Key	Effect
Fn + F1	Decreases the display's brightness.
Fn + F2	Increases the display's brightness.
Fn + F3	Decreases the display's contrast (non-TFT displays only).
Fn + F4	Increases the display's contrast (non-TFT displays only).
Fn + F5	Switches among the built-in display, an external display, and simultaneous displays.
Fn + F8	Toggles the embedded keypad on and off. Does not affect an external keyboard. If Num Lock is on, then the numeric functions are active—otherwise, cursor control is active.
Fn + F12	Enters Hibernate mode.
Fn + R	Enters Suspend mode.
Fn + S	Enters Standby mode.
Fn + ScrLk	Toggles Scroll Lock on and off.
Fn + UP ARROW Fn + DOWN ARROW	Increases and decreases the sound volume.

Resetting the OmniBook

1. Use a pen or a straightened paper clip to push the system-off button on the left side of the OmniBook. (The switch is on the motherboard.)

–or–

Press and hold the blue power button until the display shuts down. (The switch is on the VGA PCA.)

2. After the computer shuts down, press the blue power button to turn it back on.

Note

The OmniBook can boot from a CD if all these conditions are true:

- You have an internal CD-ROM drive installed,
- You have a bootable CD in the drive, such as the OmniBook Recovery CD, and
- You select the CD-ROM drive as the boot device. You can do this during reboot by pressing ESC to cancel the OmniBook screen, then ESC to display the boot-device menu for a one-time selection.

System Resources

Below are default values for system resources. To see other, non-default possibilities, use the BIOS Setup utility (see page 3-23), which lists port and audio device configurations in the System Devices menu.

The tables in this section show typical resource usage as set up by the OmniBook BIOS. Plug-and-play operating systems, drivers, and BIOS Setup settings may change some of the entries.

Table 1-7. System Interrupts

0	System timer
1	Keyboard
2	Cascade IRQ 9
3	Free (or COM2 infrared port, if enabled)
4	COM1 (serial port)
5	Crystal sound
6	Floppy drive
7	LPT1 (ECP parallel port)
8	Real-time clock
9	Free
10	USB and CardBus - assigned by Windows driver
11	Free
12	Pointing device
13	Numeric data processor
14	Internal hard disk (primary IDE controller)
15	Internal CD-ROM drive (secondary IDE controller)

Table 1-8. System Memory

00000 - 9FFFF	System memory
A0000 - BFFFF	Video
C0000 - CBFFF	Video BIOS
CC000 - DBFFF*	Free**
DC000*- FFFFF	System BIOS
* Approximate boundary.	
** Valid uses for memory addresses CC000-DBFFF: Upper memory blocks (UMBs). PC card memory windows.	

Table 1-9. System Input/Output Addresses (100-3FF)

170-177	Internal CD-ROM drive (secondary IDE controller)
1F0-1F7	Internal hard disk (primary IDE controller)
220-22F	Crystal sound
376	Internal CD-ROM drive (secondary IDE controller)
378-37F	LPT1 (printer port)
388-38B	Sound
3B0-3BB	VGA adapter
3C0-3DF	VGA adapter
3E0-3E1	PCMCIA controller
3F0-3F5	Floppy controller
3F6	Internal hard disk (primary IDE controller)
3F7	Floppy controller
3F8-3FF	COM1 (serial port)

Table 1-10. DMA Channels

0	Sound record
1	Sound playback
2	Floppy drive
3	LPT1 (ECP parallel port)
4	Cascade
5	Free
6	Free
7	Free

Specifications

The following tables list descriptions for the OmniBook and its accessories.

Table 1-11. OmniBook 4100 Specifications

Physical Attributes	Size: 330.5mm×256.9mm×35-36.5mm (13.0"×10.1"×1.3-1.4"). Weight: 2.92 kg (6.45 lb).
Processor and Bus Architecture	233/266-MHz Intel Pentium II processor with MMX technology. –or– 266-MHz Intel Pentium processor with MMX technology. 1.6-V core, 2.5-V external, low-power processor. 32-KB (16-KB instruction, 16-KB data) L1 cache. 512-KB pipeline-burst-synchronous L2 cache. 32-bit PCI bus.
Graphics	14.1- or 13.3-inch XGA active-matrix (TFT) display (1024 × 768 × 64K colors). 128-bit NeoMagic MagicGraph graphics accelerator with 2-MB video RAM. Zoomed Video support for both PC Card slots.
Power	Rechargeable 9-cell lithium ion battery with LED charge-level gauge (10.8 Vdc, 4.2 AH, 45 watt-hours). Battery life (one battery): up to 3 hours (varies with type of usage). Fast battery recharge: 80% in 1 hour, 100% in 1.5 hours. Low-battery warning. Suspend/resume capability. 60-watt ac adapter: 100 to 240 Vac (50 to 60 Hz) input, 19 Vdc, 3.16 A output.
Mass Storage	6.4-GB or 4.0-GB removable hard drive. Standard 1.44-MB floppy drive module. Standard 24X CD-ROM drive module. Optional LS-120 SuperDisk module.
RAM	32-MB SDRAM on board. One slot for RAM expansion up to 96 MB (160 MB maximum with future memory technologies).
Audio System	16-bit, Sound Blaster Pro-compatible. SRS 3D enhanced audio. Stereo sound via two built-in speakers. Built-in microphone. Line-in, headphone-out, and microphone-in.
Keyboard and Pointing Device	87/88-key touch-type QWERTY keyboard with 101/102 key emulation. Embedded numeric keypad. 12 function (Fn) keys. Two pointing devices: pointing stick (technology licensed from IBM) and touch pad.
Input/Output	Universal serial bus (USB). 9-pin, 115,200-bps serial (16550 UART). 25-pin bi-directional ECP/EPP parallel. Video-out (up to 1024×768×64K colors at 85-Hz refresh rate). PS/2 keyboard/mouse. 4-Mbps IrDA-compliant infrared port.
Expandability	One Type III or two Type II 16-/32-bit PC Card slots (3.3- and 5-V support). CardBus enabled. Plug-in module bay for accessory modules. Optional port replicator, mini dock, and docking system.

Preinstalled Software	<p>Microsoft Windows 95 or Windows NT 4.0. Windows 95-compatible Plug-and-Play. Windows NT 4.0 APM and PC Card Plug-and-Play. Advanced Power Management (APM 1.2). DMI 2.0 with HP TopTools 2.6. McAfee Virus Scan 3.1.5. Online documentation. OmniBook Recovery CD-ROM included. Centralized worldwide BIOS and driver update service.</p>
Security Features	<p>User and administrator passwords. System, hard drive, and docking passwords. PC identification displayed at boot. DMI-accessible electronic serial number. Kensington Microsaver lock slot.</p>
Environmental Limits	<p>Operating temperature: 5 to 35 °C (41 to 95 °F). Operating humidity: 20 to 90 percent RH (5 to 35 °C). Storage temperature: -20 to 50 °C (-4 to 122 °F).</p>
Major ICs	<p>CPU: Intel Mobile Pentium or Pentium II. South Bridge: PIIX4E. Video: NeoMagic MagicGraph NM2160. Audio: Crystal CS4237B. CardBus: TI PCI1250A. Keyboard controller: National PC87570. Super I/O: SMC 769.</p>

Table 1-12. OmniBook 4100 Accessories

OmniBook 4100-Only Accessories	
F1474A	24X CD-ROM drive module.
F1472A	Floppy drive module.
F1473A	Floppy drive cable for external use.
F1466A	Lithium-ion battery (primary and secondary).
F1467A	4.0-GB internal hard disk drive.
F1475A	6.4-GB internal hard disk drive.
F1470A	LS-120 SuperDisk drive module.
OmniBook 7100, 4100, 3100, 2100 Accessories	
F1477A	Docking system and monitor stand (tall).
F1452A	Mini dock.
F1451A	Port replicator.
F1453A	Monitor stand (short).
F1456A	32-MB RAM expansion card (7100/4100 only).
F1457A	64-MB RAM expansion card (7100/4100 only).
F1454A	60-watt ac adapter.
F1455A	75-watt auto/airline power adapter.
F1469A	PS/2 Y-adapter.
TMC3X575	10/100-Mbps Ethernet PC Card.
TMC3C589	10-Mbps Ethernet PC Card.
XIRCM56T	56-Kbps modem PC Card.
8120-6313	Replacement power cord (U.S., Canada, Taiwan).
8120-6314	Replacement power cord (Europe).
8120-6315	Replacement power cord (Hong Kong, Singapore, U.K.).
8120-6312	Replacement power cord (Australia).
8120-6316	Replacement power cord (Japan).
8120-6317	Replacement power cord (India, South Africa).
8120-8373	Replacement power cord (People's Republic of China).

Internal Design

The motherboard PCA is the central component of the OmniBook design. It plays a role in virtually all system functions. The CPU module (MMO) and most other subsystems connect to the motherboard.

The following figure shows the connections among the replaceable electrical modules. As a substitute for a functional block diagram, see the table on page 1-13—it lists the roles the replaceable modules play in each of the functional subsystems.

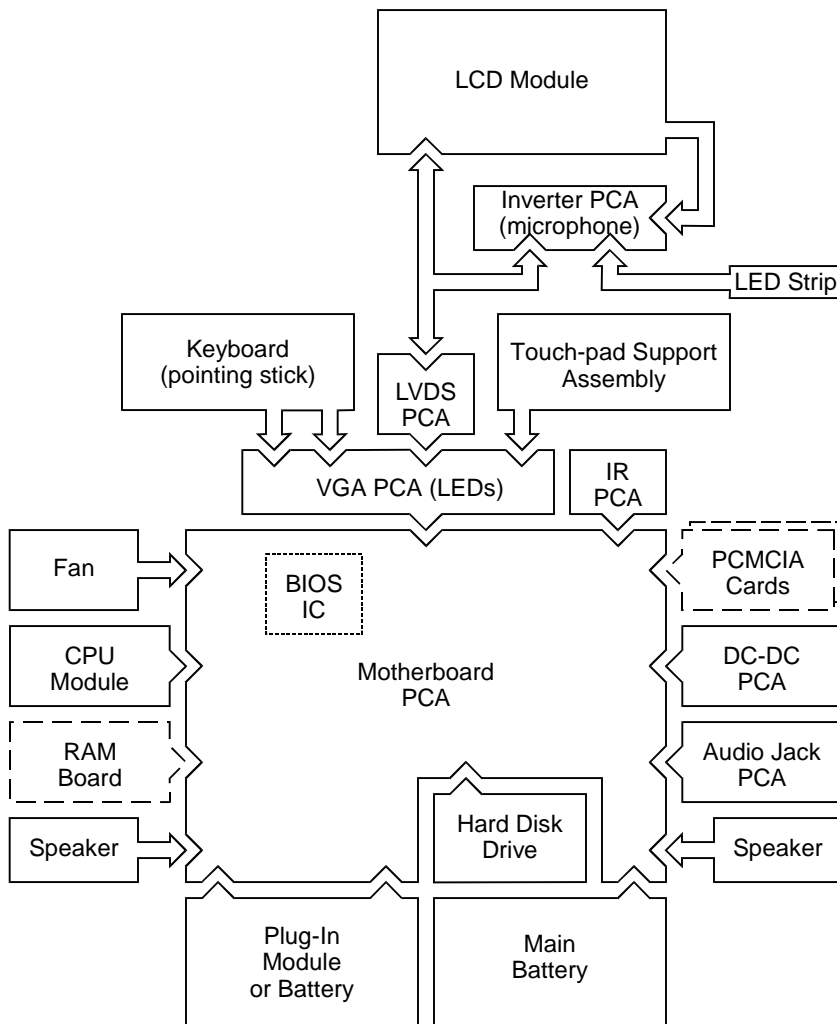

The power switch and lid switch are contained on the motherboard.

All external connections (except IR and audio) are made to the motherboard.

Figure 1-4. Replaceable Module Diagram

Table 1-13. Functional Structure

Bootup	CPU module Motherboard BIOS IC Floppy disk module Hard disk drive	Main processor (MMO). Primary system circuitry. Code for basic system functions. First source of disk-based startup code. Second source of disk-based startup code.
Processor	CPU module Motherboard	Main processor, numeric data processor, L1 and L2 cache. Primary system circuitry.
Memory	Motherboard RAM board VGA PCA	First 32 MB of RAM. Optional, additional RAM. Video RAM.
Power	Battery Motherboard DC-DC PCA AC adapter	Power storage. AC adapter socket, power switch, lid switch, system-off switch, power supply. Power control circuitry. AC-to-dc converter.
Display	Motherboard LCD module Inverter PCA LVDS PCA VGA PCA	PCMCIA/zoomed video controller. Display output, backlight. Power converter for backlight. Display drivers, signal processing. (Low-Voltage Differential Signaling) Display/graphics controller, video RAM.
Hard disk	Motherboard Hard disk drive	Hard disk controller. Hard disk mechanism.
Floppy drive	Motherboard Floppy disk module	Floppy disk controller. Floppy disk mechanism.
Keyboard	Motherboard BIOS IC Keyboard	Keyboard controller. Keyboard BIOS. Key switches.
Pointer	Motherboard Keyboard Touch-pad support	Keyboard controller, pointing stick controller (PS/2 output). Pointing stick sensor. Touch pad sensor, controller (PS/2 output).
Audio	Motherboard Audio jack PCA Inverter PCA Speakers	Audio controller, speaker amplifier, headphone amplifier, zoomed video controller, mute switch. External audio jacks. Microphone. Speakers.
Status	Motherboard LED strip cable VGA PCA	Keyboard controller. Power LEDs. Keyboard LEDs.
Serial	Motherboard	I/O controller, serial connector.
Parallel	Motherboard	I/O controller, parallel connector.
Infrared	Motherboard IR PCA	I/O controller. Infrared transmitter/receiver.
PS/2 port	Motherboard	Keyboard controller, PS/2 processor, PS/2 connector.
USB	Motherboard	Bus controller (South Bridge), USB connector.
Docking port	Motherboard	Docking logic, docking connector.
PCMCIA	Motherboard PCMCIA socket	PCMCIA controller. PCMCIA connectors.

Removal and Replacement

This chapter tells you how to remove and replace the following components and assemblies. The ones marked by • are user-replaceable.

Table 2-1. Removal Cross-Reference

Air vent cover (table on page 2-23).	I/O door (table on page 2-7).
Audio jack cover (table on page 2-23).	IR PCA (table on page 2-23).
Audio jack PCA (table on page 2-23).	Keyboard (page 2-8).
• Battery (page 2-3).	LCD brackets (table on page 2-21).
BIOS IC (page 2-19).	LCD flex cable (table on page 2-21).
Bottom case (page 2-16).	LCD module (page 2-11).
Cable holder (table on page 2-21).	LCD shield (table on page 2-21).
CPU bottom plate (table on page 2-23).	LED strip cable (table on page 2-21).
CPU module (table on page 2-23).	LVDS PCA (table on page 2-23).
CPU top plate (table on page 2-23).	Module latch (table on page 2-23).
DC-DC PCA (table on page 2-23).	Motherboard (page 2-16).
Display bezel (table on page 2-21).	PCMCIA socket (table on page 2-23).
Display case (table on page 2-21).	• Plug-in module (page 2-3).
Display latch (table on page 2-21).	• RAM board (page 2-4).
Docking door (table on page 2-7).	• RAM/BIOS cover (table on page 2-7).
End cap (table on page 2-21).	Speaker cover (table on page 2-23).
Fan (table on page 2-23).	Speaker (table on page 2-23).
• Foot (table on page 2-7).	Strip cover (table on page 2-22).
Frame (table on page 2-23).	Top case (page 2-14).
• Hard disk drive (page 2-5).	Touch-pad flex cable (table on page 2-22).
Heatsink parts (table on page 2-23).	Touch-pad support (table on page 2-22).
Hinge (table on page 2-21).	• VGA connector cover (table on page 2-7).
Hinge cover (table on page 2-21).	VGA PCA (table on page 2-23).
Inverter PCA (table on page 2-21).	

Caution

Always provide proper grounding when performing repairs. Without proper grounding, an electrostatic discharge may damage the OmniBook and its components.

Notes

Reassembly steps are the reverse of the removal steps. Reassembly notes are included at the end of each section below.

 Symbols like this throughout this chapter show approximate full-size screw outlines. You can use them to verify the sizes of screws before you install them. Installing a wrong-size screw can damage the unit. (The symbol at the left represents an M2.5x5mm T-head screw.)

Table 2-2. Required Equipment

- Small Phillips screwdriver, preferably magnetized.
- 5 mm hex driver.
- Pointed knife or probe.
- Small flat-blade screwdriver.
- IC insertion/removal tool.

Table 2-3. Recommended Screw Torques

Screw Thread Size	Torque (kgf•cm)	Torque (in•lbf)
M2	1.0 – 1.5	0.9 – 1.3
M2.5 (5 mm)	3.0 – 3.5	2.6 – 3.0
M2.5 (16–19 mm)	2.5 – 3.0	2.2 – 2.6
M3	3.0 – 3.5	2.6 – 3.0

Removing the Battery or Plug-In Module (User-Replaceable)

Required Equipment

- None.

Removal Procedure

1. Unplug the ac adapter, if present.
2. Slide forward the module latch slider on the corner next to the module, then swing back the latch to loosen the module.
3. Pull out the module.
4. Slide the latch back into the case.

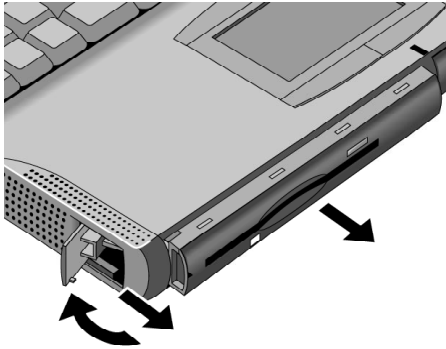

Figure 2-1. Removing the Battery or Plug-In Module

Reassembly Notes

- **Important:** You must slide the latch forward before you can insert a module.
- You can install a battery in either bay. But any other type of module must be installed in only the left bay.

Removing a RAM Board

(User-Replaceable)

Table 2-4. RAM Board Replacement Part Numbers

Description	Part Number	Exchange Part Number
RAM board, 32-MB	1818-7413	F1456-69100
RAM board, 64-MB	1818-7414	F1457-69100

Caution

Handle the RAM board only by its edges and provide proper grounding. Otherwise, you may damage the board due to electrostatic discharge.

Required Equipment

- Small Phillips screwdriver.

Removal Procedure

1. Unplug the ac adapter, if present, and remove the battery.
2. Turn the unit bottom side up, then remove the two screws from the RAM/BIOS cover and remove the cover.
3. Release the two latches at the sides of the RAM board, so the free edge of the board pops up.
4. Pull the board out of the connector.

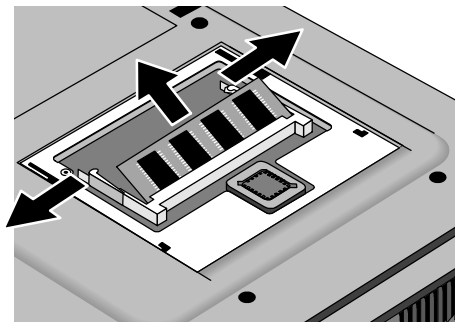

Figure 2-2. Removing a RAM Board

Reassembly Notes

- Insert the RAM board into the connector at about a 30° angle until it is fully inserted. Then press down at both sides until both latches snap closed.

Removing the Hard Disk Drive

(User-Replaceable)

Table 2-5. Hard Disk Drive Replacement Part Numbers

Description	Part Number	Exchange Part Number
Drive, hard disk (4.0GB, IBM)	0950-2671	F1386-69100
Drive, hard disk (4.0GB, Toshiba)	0950-2865	F1386-69101
Drive, hard disk (6.4GB, IBM)	0950-2785	F1475-69100

Required Equipment

- Small Phillips screwdriver.
- Small flat-blade screwdriver.

Removal Procedure

1. Unplug the ac adapter, if present, and remove the battery.
2. Turn the unit bottom side up.
3. Remove the hard drive screw from the bottom case.
4. Pull out the hard drive by its plastic tab.

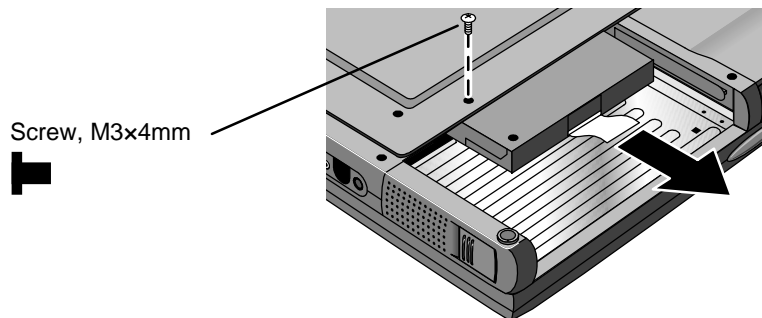

Figure 2-3. Removing the Hard Disk Drive

5. If you are installing a new hard drive that does not have a cover, you can remove the cover parts from the old hard drive:
 - Remove the screw from the case, then pry open the flap. If necessary, use a flat-blade screwdriver
 - Use a flat-blade screwdriver to pry open the snaps at the ends of the case, then open the connector-side of the case.
 - Pry out the corner next to the connector, then lift out the connector and hard drive together.
 - Unplug the internal connector and cable from the hard drive.

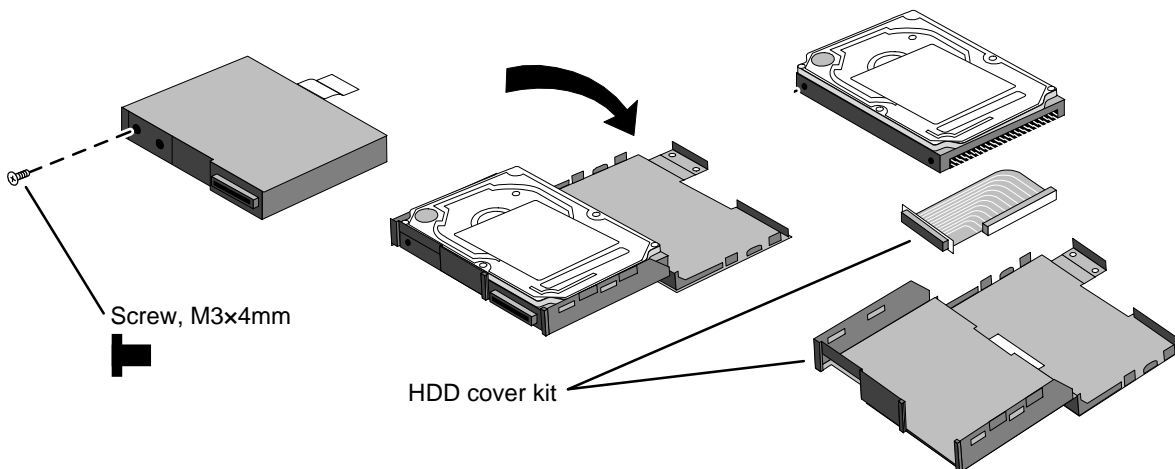

Figure 2-4. Installing a Hard Drive in the Cover

Reassembly Notes

Caution

Do not cover the vent hole in the top surface of the hard drive or in the case. If you cover the hole, the hard drive could fail prematurely.

- Pry out the connector corner of the case and insert the external connector and hard drive at the same time. The connector seats in the lower part of the opening in the case.
- Secure the two tabs on the screw flap by inserting the corner tab last, while prying out the nearby corner of the case.
- When you install the battery module, be sure the plastic tab on the hard drive case lays folds up against the front of the case.

Important

- If you are installing a new hard drive, you should create a Hibernate partition on the drive before loading any software—see the steps below.

Creating a Hibernate Partition

1. If you do not have an OmniBook Recovery CD and internal CD-ROM module for the computer you are repairing, create a Support Utility floppy disk now.

After inserting a formatted floppy disk in the floppy drive, do one of the following:

- On a factory software installation, click Start, Programs, OmniBook, Create Support Utility Disk.
- On any computer that has a CD-ROM drive, run **makesupp** from the \OmniBook\Drivers\Hputils directory on the OmniBook 4100 Recovery CD.
- On any computer with World Wide Web access, download the Support Utility software package from the OmniBook website (see page vi). Follow the instructions provided.

2. Insert the Recovery CD in the CD-ROM drive—or insert the Support Utility disk in the floppy drive.

3. Reboot the computer. If you are using the Recovery CD, press ESC during reboot to cancel the OmniBook screen, ESC to display the boot-device menu, then select the CD-ROM drive as the boot device.
 4. When prompted, select “Create Hibernate Partition.”
- We recommend that you create a 96-MB partition, the same as the factory setup.

Replacing Small Parts (User-Replaceable)

The following small parts are user-replaceable.

Table 2-6. Replacing Small Parts (User-Replaceable)

Part	Replacement Procedure
Docking Doors	Open each door and flex the door until one side tab releases. To replace, see the picture on page 2-19.
Feet	Insert a small flat-blade screwdriver under the foot and pry it loose. To replace, firmly press the adhesive side of the foot into the recess.
I/O Door	With the door closed, insert a small flat-blade screwdriver behind the door from below. Flex the door until one side tab releases. It helps to press in lightly on the ends of the door.
Pointing Stick Cap	Pull the cap off the pointing stick.
RAM/BIOS Cover	On the bottom of the unit, remove the two screws from the RAM/BIOS cover and remove the cover.
VGA Connector Cover	With the display closed, push up on the cover and down on the bottom case until the lower tabs release. To install, insert the top tabs into the strip cover, then push up on the cover and down on the bottom case until you can insert the lower tabs.

Removing the Keyboard

(HP Authorized Service Providers Only)

Required Equipment

- Small Phillips screwdriver.
- Probe or tweezers.

Removal Procedure

1. Unplug the ac adapter, if present, and remove the battery.
2. On the bottom of the unit, remove the seven “K” screws from the bottom case.
3. Insert your small finger into the PCMCIA opening and push up the top of the keyboard—or you can lift it from above using a thin flat-blade screwdriver. After lifting the back edge slightly, slide the keyboard toward the back until the front-left corner is free.
4. With the display tilted only slightly back, lift the front of the keyboard and lean it back against the display. Be careful not to scratch the display or pull on the cables.
5. Release the pointing stick flex cable from the VGA PCA.
6. Release the keyboard flex cable from the VGA PCA.

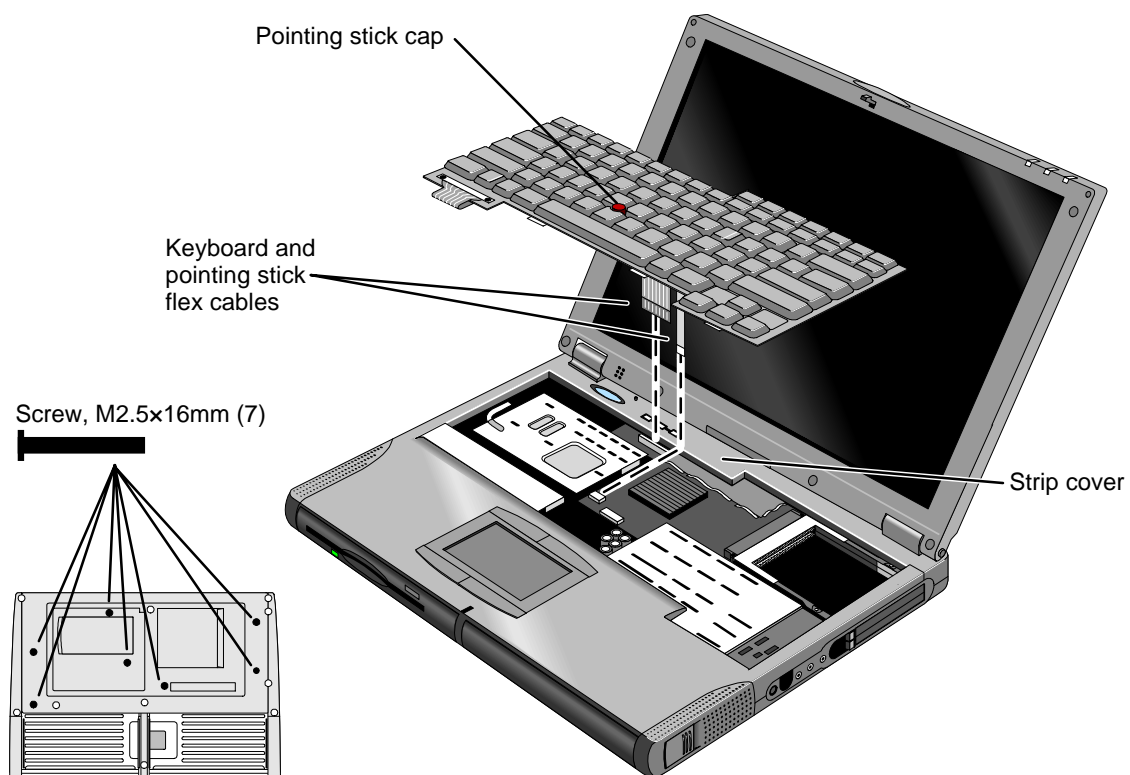

Figure 2-5. Removing the Keyboard

Reassembly Notes

Caution

After connecting the keyboard and pointing stick flex cables, lean the keyboard forward and tuck the excess length of the keyboard flex cable under the strip cover behind the keyboard. If a stiffener tab is present on the larger cable, make sure its free end lays toward the front of the case—so the tab is not under the strip cover. *Check the cable again after lowering the keyboard into its final position.*

Hint

On the bottom case, the holes for the keyboard screws are marked by “K”. The hole recesses have flat bottoms for the 16-mm T-head screws (not tapered as for longer flathead screws).

Removing the Display Assembly

(HP Authorized Service Providers Only)

Required Equipment

- Small Phillips screwdriver.

Removal Procedure

1. Unplug the ac adapter, if present, and remove the battery.
2. On the back of the unit, lift up on the VGA connector cover above the VGA port and unsnap it from the case.
3. Remove the screw above the VGA port.
4. Remove the four “D” screws from the bottom case.
5. Open the display about 90 degrees, then lift off and lay back the combined top-case strip cover and display assembly.
6. Remove the two screws from the LCD flex cable end and unplug the cable.

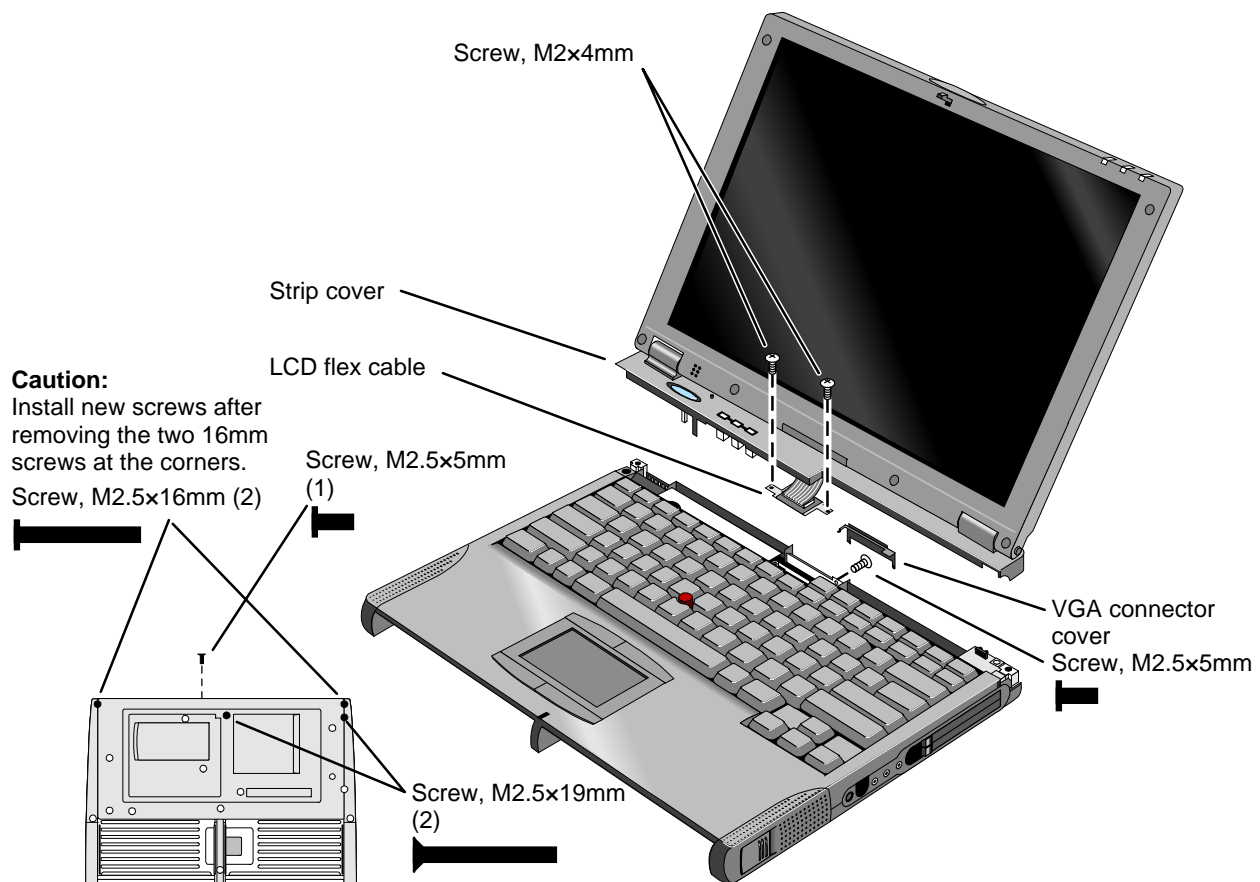

Figure 2-6. Removing the Display

Reassembly Notes

Caution

Install new screws for all screws you remove that hold the display hinges. Otherwise, the hinges could loosen over time.

Hint

- While attaching the LCD flex cable to the LVDS PCA, rest one corner of the display on the bottom case.
- On the bottom case, the holes for the display screws are marked by "D". The hole recesses have flat bottoms for the 16-mm T-head screws and tapered bottoms for the longer 19-mm flathead screws.

Removing the LCD Module

(HP Authorized Service Providers Only)

Note

The exact details for removing the LCD module depend on the type of module. Some details may differ from those described below.

See the table below for information about matching components for different types of LCD modules.

To identify the type of LCD module, see the marking printed on the LCD flex cable where it plugs into the LVDS PCA in the bottom case.

Table 2-7. Display Component Compatibility

Display Type	LCD Module	LCD Flex Cable	LCD Kit (brackets...)	Inverter PCA	LVDS PCA	Display Case	Display Bezel
13" Samsung	F1460-69098	F1460-60975	F1460-60974	F1460-60917	F1460-60914	F1460-60970	F1460-60969
14" LG	F1440-69095	F1460-60981	F1460-60980	F1460-60918	F1460-60916	F1460-60968	F1460-60967

Required Equipment

- Small Phillips screwdriver.
- Pointed knife or probe.

Removal Procedure

1. Unplug the ac adapter, if present, and remove the battery.
2. Remove the display assembly and strip cover from the unit (page 2-10).
3. On the display bezel, remove the upper and lower screw covers (using a pointed knife or probe), then remove the six screws.
4. At the bottom of the display, lift up the inner edge of the bezel near both hinges until it unsnaps—be careful to keep the end caps. Then at one side of the display, use your fingers to gently pull the display bezel *outward*, toward the edge of the case, until the snaps release. When one side is free, repeat along the opposite side—until only the top edge is attached.
5. Now lift the bottom edge about 5 cm and press *inward* along the top edge until the snaps release and the bezel lifts off.

6. Remove the two screws holding the LCD brackets and hinges near the bottom corners of the display case. Remove the combined hinges and strip cover.
7. On the plastic cable holder, unsnap the cover.
8. If present, unplug the flex cable that wraps around the inverter PCA to the left of the cable holder.
9. Raise the inverter PCA out of the case and unplug the three cables. Remove the PCA.
10. Slide the LCD module and brackets toward the bottom of the case. When the slots in the brackets clear the tabs in the case, lift out the LCD module—the LED strip cable is still in the display case.
11. If the LED strip cable is held by the LCD bracket, lift the right tab of the LED strip where it fits into the display case. Lift the strip out of the case.
12. Remove the four screws holding the brackets to the LCD module.
13. Separate the LCD module and the shield:
 - You may have to remove one or more pieces of tape.
 - If the flex cable is still attached to the LCD module, unplug the cable.

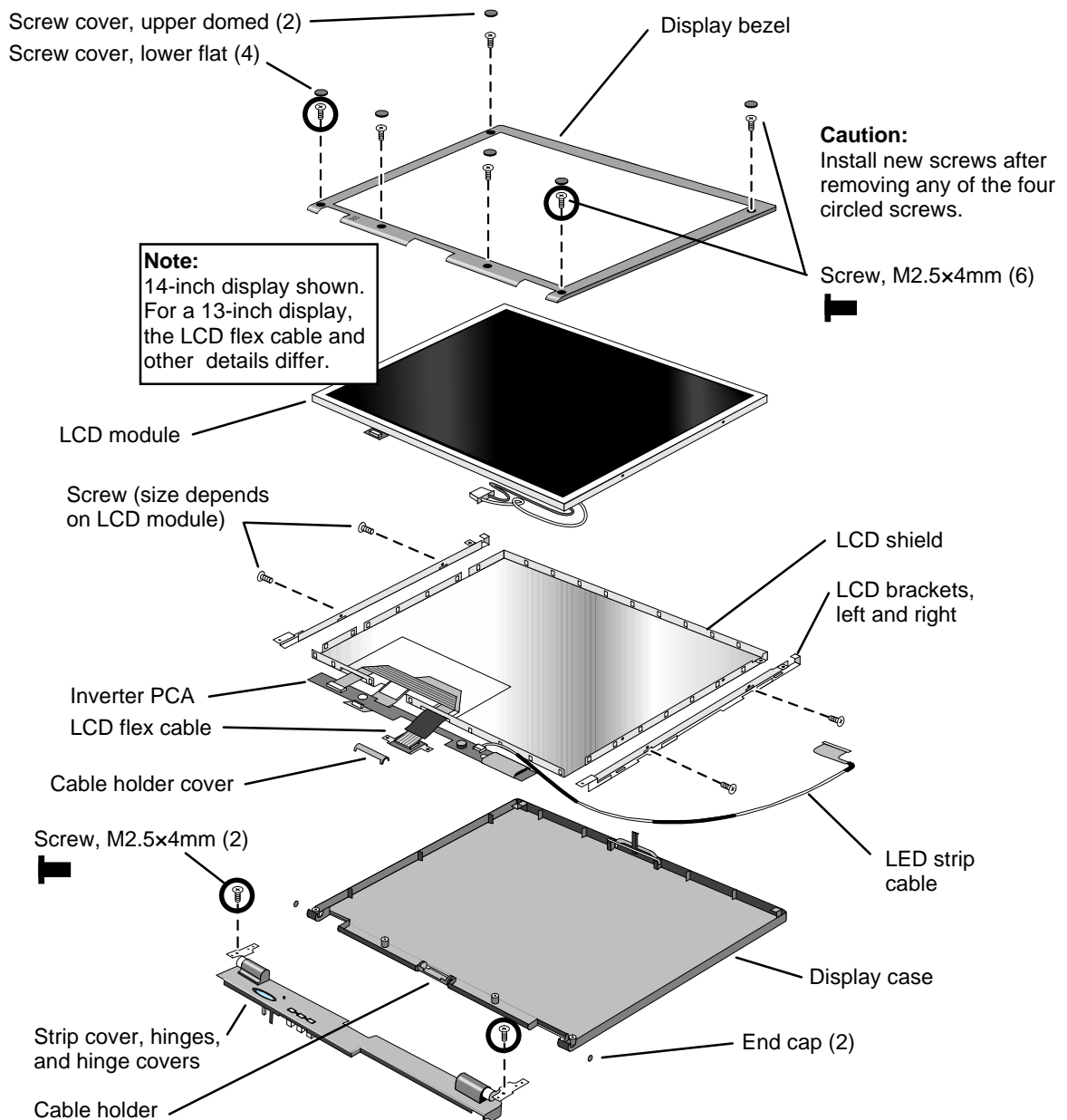

Figure 2-7. Removing the Display

Reassembly Notes

Caution

- Be sure to replace the LCD module or other display components with compatible parts. Components may be damaged if compatible parts are not used. See the table on page 2-11.
- Install new screws for all screws you remove that hold the display hinges. Otherwise, the hinges could loosen over time.

- Make sure the LED strip cable is routed through the bottom-right corner of the LCD bracket.
- Install the inverter PCA *under* the main LCD flex cable.

- The extra length of LCD wires connecting to the inverter PCA is folded back along the PCA.
- Snap in the end caps after the display is assembled.

Caution

At the lower-right corner of the LCD module, be careful the wires are not pinched where they pass next to the LCD bracket. Otherwise, they could be damaged.

Removing the Top Case

(HP Authorized Service Providers Only)

Required Equipment

- Small Phillips screwdriver.

Removal Procedure

1. Unplug the ac adapter, if present, and remove the battery.
2. Remove these additional assemblies:
 - Floppy module or other module (page 2-3).
 - Hard disk drive (page 2-5).
 - Keyboard (page 2-8).
 - Display assembly and strip cover (page 2-10).
3. On each of the front corners of the case, do the following:
 - Slide the module latch slider forward on the side of the case.
 - Slide the speaker cover forward slightly and swing it outward about 2 cm, then pull firmly until it unsnaps from the case. The slider may come off of the module latch.
4. Unplug the touch-pad flex cable from the VGA PCA.
5. On the bottom of the unit, remove the seven unmarked case screws from the front half of the case.
6. Turn the unit face up and lift off the top case.

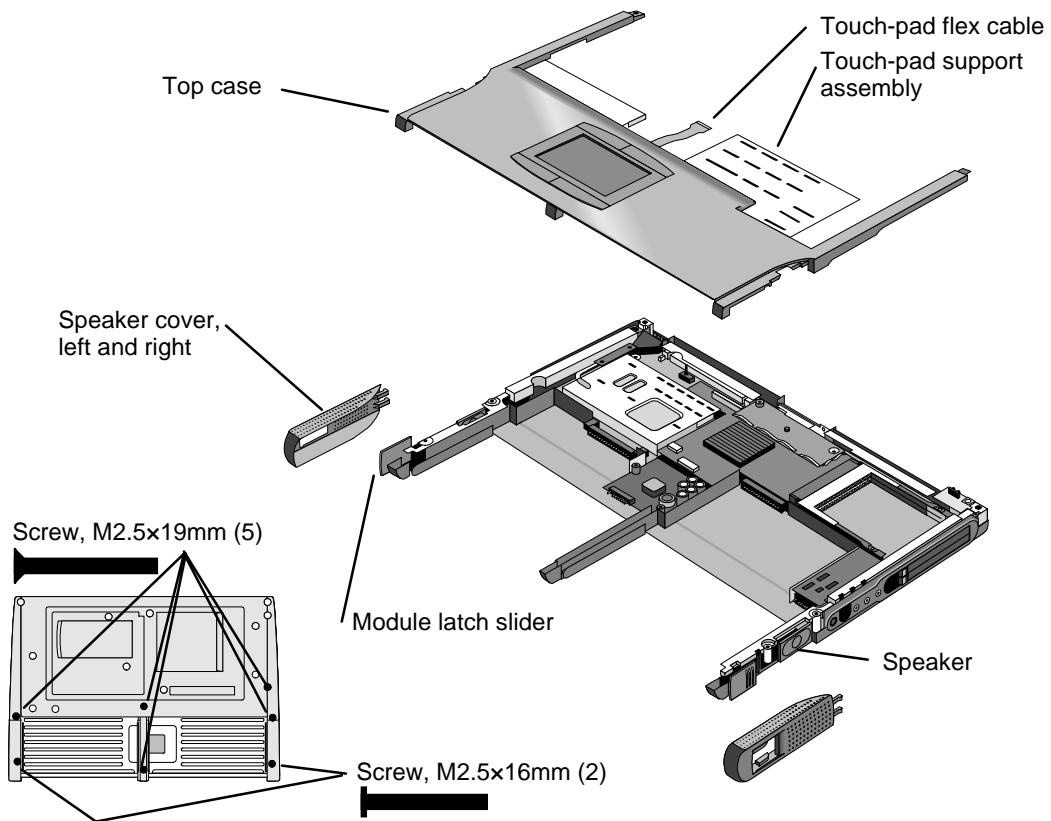

Figure 2-8. Removing the Top Case

Reassembly Notes

Note: Installing a New Top Case

Transfer the touch-pad support assembly from the old top case to the new one.

- Before installing the screws, make sure the front edge of the plate is held by the four plastic tabs on the top case.
- Check the click buttons—make sure you can feel the “click” in all four buttons. After assembly, check their operation.

- Position the speaker on the pins on the bottom case before you install the speaker cover.
- If the slider came off the module latch, attach it to the latch before you install the speaker cover.

Hint

On the bottom case, the holes for the top case screws are unmarked. The hole recesses have flat bottoms for the 16-mm T-head screws and tapered bottoms for the longer 19-mm flathead screws.

Removing the Motherboard or Bottom Case

(HP Authorized Service Providers Only)

Required Equipment

- Small Phillips screwdriver.
- 5-mm hex driver (or 3/16 inch).

Removal Procedure

1. Unplug the ac adapter, if present, and remove the battery.
2. Remove these additional assemblies:
 - Floppy module or other module (page 2-3).
 - Hard disk drive (page 2-5).
 - Keyboard (page 2-8).
 - Display assembly (page 2-10).
 - Top case (page 2-14).
3. Remove the screw from the heatsink cover and lift it off the heatpipe.
4. Remove the two screws from the CPU top plate, then lift the right half of the complete CPU assembly so it unplugs from the motherboard.
5. On the back of the case, use a 5-mm hex driver to remove the two standoffs from the VGA connector.
6. Lift the front of the VGA PCA to unplug the PCA, then slide it out of the case. (The LVDS PCA is attached.)
7. Remove the screw from the IR PCA and lift the PCA off the frame. Unplug the IR cable from the motherboard.
8. On the left frame, remove the screw that holds the plastic heat exchange cover, then lift off the cover.
9. Unplug the fan cable from the motherboard and lift out the fan.
10. On the left frame, remove the screw that holds the frame to the motherboard, then lift out the frame.
11. Lift out the side air vent cover and finned heatsink at the left side of the case.
12. On the right frame, remove the two screws that hold the frame to the case, then lift out the frame.
13. Remove the screw holding the motherboard at the back-right corner.
14. Unplug the DC-DC PCA from the right side of the motherboard.
15. Lift the front-right corner of the motherboard and remove the audio jack cover from the case.
16. Unplug the audio jack PCA from the motherboard.
17. Note the routing of the speaker wires. Then unplug the speaker wires from the motherboard.
18. Remove the two screws from the RAM/BIOS cover and remove it from the bottom of the unit.

Hint

In the next step, while removing the motherboard, reach through the RAM opening and separate the case from the PCA. Otherwise, the PCA sticks in the bottom case.

19. Lift the front edge of the motherboard until it clears the hard drive compartment in the bottom case and frees itself from the bottom case. Then slide the PCA forward and lift it out.

The docking doors may come out while you are removing the motherboard.

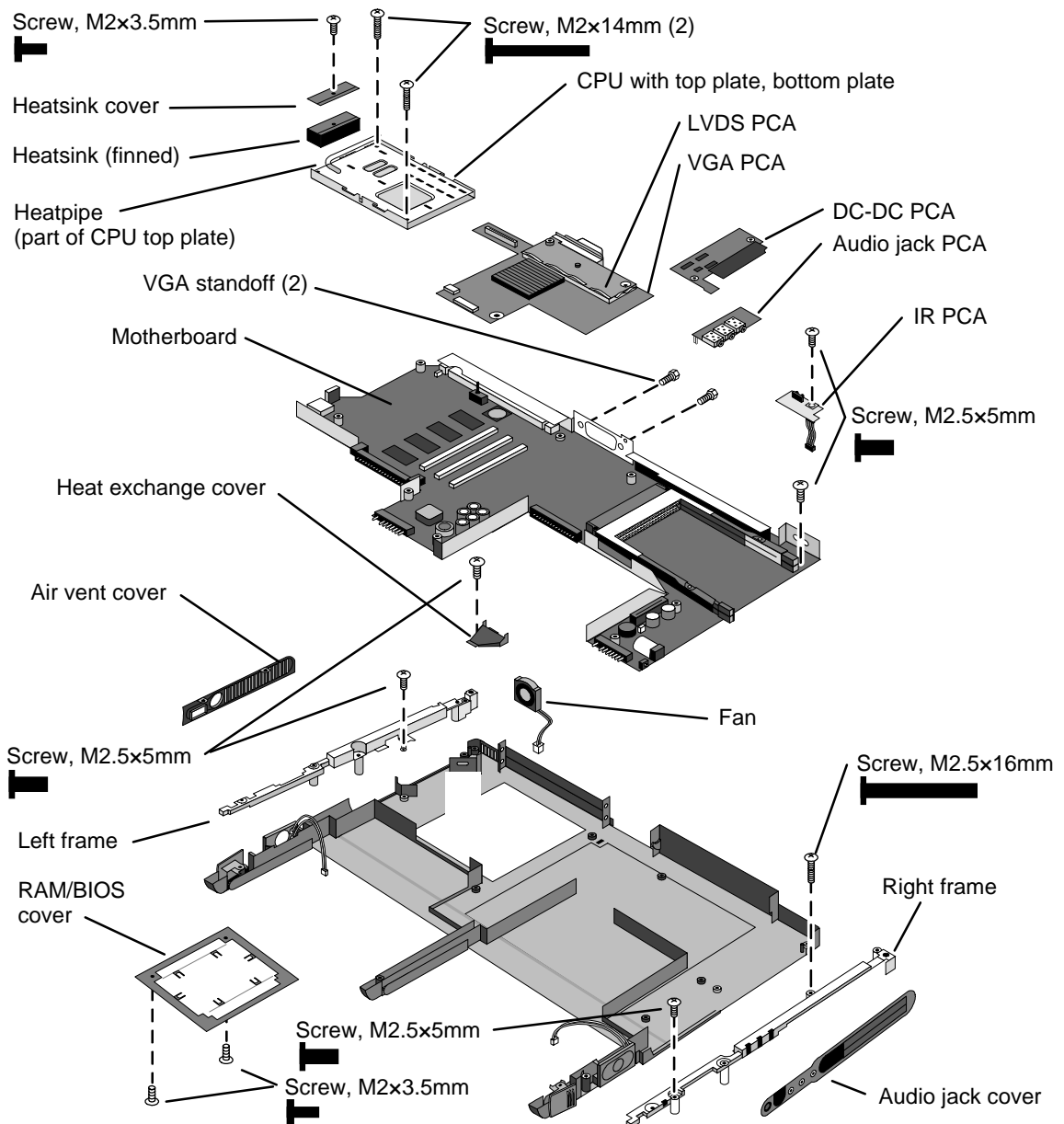

Figure 2-9. Removing the Motherboard

Reassembly Notes

Note: Installing a New Motherboard

- If a RAM board is present, transfer it from the old motherboard to the new one:
- Reprogram the BIOS IC—see the note below.
- Store the serial number electronically in the new motherboard—see the steps below.

Note: Installing a New Bottom Case

- Transfer these parts from the old bottom case to the new one:
 - I/O door, docking doors, and module latches (see the figures below).
 - Speakers.
- Install a new regulatory/business card label.
- Install a new serial number label and overlay—see the steps below.
- Route the speaker wires so they do not get pinched or block screw holes.
- Route the fan wires at the bottom of the opening next to the motherboard.
- When attaching the IR PCA to the right frame, make sure the PCA is parallel with the back of the case.
- Before installing the CPU module, assemble it into the bottom plate and attach the top plate. Then install the complete assembly on the motherboard. See the following caution.

Caution

- Install or replace CPU module thermal pads that are missing or damaged. See the figures below.
- Keep the CPU assembly flat while installing it. Press it down above the connectors at the right end. Otherwise, you could damage the connectors.
- Install the two screws in diagonally opposite corners of the top plate.

Note

If you installed a new motherboard with a new BIOS IC, the IC contains only enough basic programming to boot the OmniBook. After installing the IC, you must reprogram it. Hewlett-Packard prefers that you program the IC with the latest BIOS—follow the directions carefully. You can download it from the OmniBook website (see page vi).

Note: View from inside the case.
Rotate the doors 360° to load the spring.

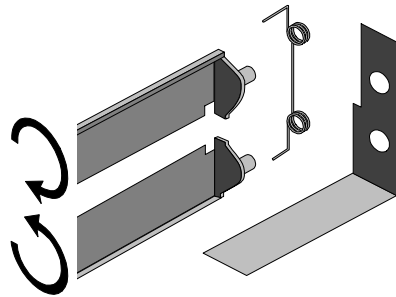

Note: Left latch shown.
Rotate the latch 180° to load the spring.

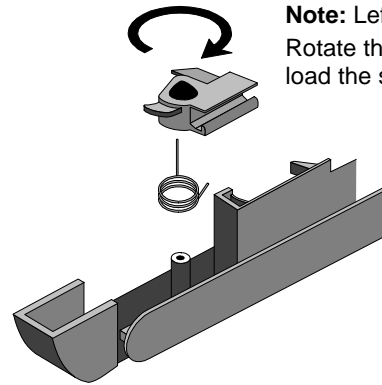
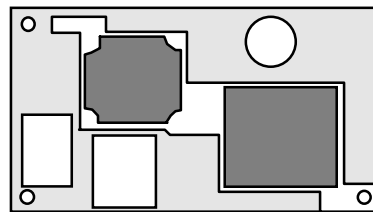
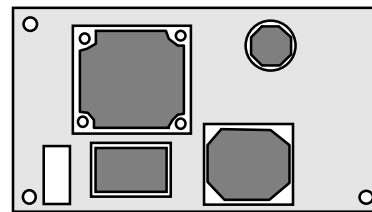

Figure 2-10. Installing Docking Doors and Module Latch



CPU module, Pentium II (MD)
(2 thermal pads)



CPU module, Pentium (T)
(4 thermal pads)

Figure 2-11. Positioning Thermal Pads

Storing the Serial Number Electronically

1. Exit Windows and boot to a DOS prompt.
2. Run ESN.EXE from one of these sources:
 - On a factory software installation, change to the \OMNIBOOK directory and type **esn** at the prompt.
 - Otherwise, copy \Omnibook\Drivers\Hputils\Esn.exe from the OmniBook 4100 Recovery CD, then run it on the OmniBook.
3. Store the serial number:
 - If you are prompted for the serial number, type the serial number shown on the bottom of the case.
 - If a serial number has already been stored, you must call an HP support center to change it.

Installing a New Serial Number Label

If you do not have a master file that creates serial number labels, get a copy from the Reseller website (see page vi).

1. Using any PC connected to a laser printer, open the master serial label file, enter the serial number and product number from the old serial label, and print the new label on plain white paper. The new label does not have barcodes.
2. Carefully cut out the new serial label just inside the border and place it into the inner recess in the bottom case. The bottom of the label goes toward the front of the case.

3. While holding the paper label in place, attach a serial label overlay into the outer recess. It covers and protects the serial label.

Removing the BIOS IC

(HP Authorized Service Providers Only)

Note

A replacement BIOS IC contains only enough basic programming to boot the OmniBook. After installing the IC, you must reprogram it. Hewlett-Packard prefers that you program the IC with the latest BIOS—follow the directions carefully. You can download it from the OmniBook website (see page vi).

Required Equipment

- Small Phillips screwdriver.
- IC insertion/removal tool.

Removal Procedure

1. Unplug the ac adapter, if present, and remove the battery.
2. On the bottom of the unit, remove the two screws from the RAM/BIOS cover and remove the cover.
3. Use an IC insertion/removal tool to remove the BIOS IC from its socket.

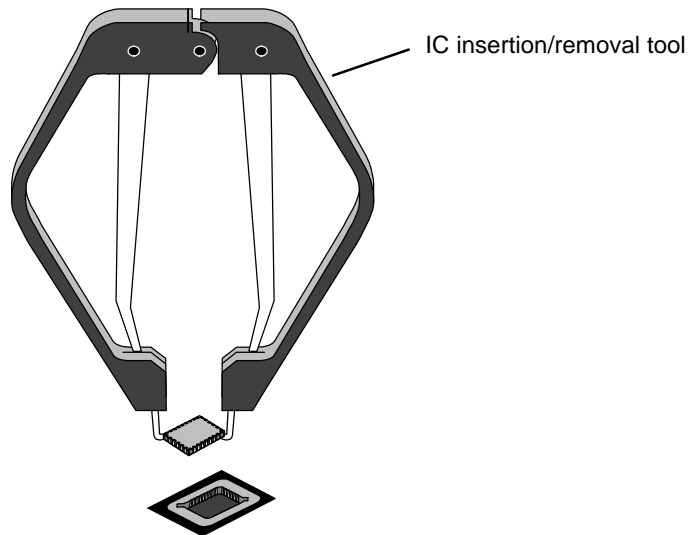

Figure 2-12. Removing the BIOS IC

Reassembly Notes

Caution

- Replace the BIOS IC with one that is compatible with the CPU module—see the table on page 4-3.
 - Align the IC with the slot in the socket. The IC is keyed to fit correctly. If you insert the IC backward, the IC or motherboard could be damaged.
-
- Press down firmly on the IC with your thumb to ensure a proper connection.
 - Reprogram the IC by programming the BIOS—see the note above.

Removing Other Components (HP Authorized Service Providers Only)

Required Equipment

- Small Phillips screwdriver.
- Pointed knife or probe (for display components).
- 5-mm hex driver (or 3/16 inch) (for bottom case components).

Removal Procedure

1. Unplug the ac adapter, if present, and remove the battery.
2. Remove the additional assemblies and follow the special steps indicated in the tables below. Components are separated into these groups:
 - Display components (below).
 - Top case components (page 2-22).
 - Bottom case components (page 2-23).

Table 2-8. Removing Display Components

Component	Removal Procedures	Additional Steps (See figure on page 4-5)
Cable Holder (part of display case kit)	Display (page 2-10).	1. Remove the display bezel (page 2-11). 2. Unsnap the cover of the cable holder. 3. Use a flat-blade screwdriver to pry the display case and release the cable holder. Reassembly Notes: Install the holder so the tabbed side is toward the bottom of the display case.
Display Bezel	Display (page 2-10)	Remove the display bezel (page 2-11). Caution: Use compatible parts (page 2-11).
Display Case	Display (page 2-10).	Remove the LCD module and brackets from the case, but do not disassemble the module (page 2-11). Reassembly Notes: Transfer the display latch and cable holder from the old display case. Caution: Use compatible parts (page 2-11).

Component	Removal Procedures	Additional Steps (See figure on page 4-5)
Display Latch (part of display case kit)	Display (page 2-10).	<ol style="list-style-type: none"> For a 13-inch display, do not remove the LCD module, but remove the display assembly and bezel (page 2-11). For a 14-inch display, remove the LCD module and brackets from the case, but do not disassemble the module (page 2-11). Use a flat-blade screwdriver or probe to release one end of the latch spring. Swing the latch into the display case, then lift it out of its holders.
End Cap	Display (page 2-10).	<ol style="list-style-type: none"> Remove the display bezel (page 2-11). Lift out the end cap.
Hinge	Display (page 2-10).	<ol style="list-style-type: none"> Remove the display bezel (page 2-11). Remove the hinges and strip cover from the LCD brackets, then unsnap the hinge covers.
Hinge Cover	Display (page 2-10).	<ol style="list-style-type: none"> Unsnap the hinge cover from the strip cover. Remove the hinge cover. You may have to change the hinge position to free the hinge cover.
Inverter PCA	Display (page 2-10).	<ol style="list-style-type: none"> Remove the display bezel (page 2-11). On the plastic cable holder, unsnap the cover. Unplug all cables attached to or holding the inverter PCA. Lift up the PCA if necessary. <p>Reassembly Notes: Attach cables with tape as in the original unit. Caution: Use compatible parts (page 2-11).</p>
LCD Brackets (part of LCD kit)	Display (page 2-10). LCD module (page 2-11).	Caution: Use compatible parts (page 2-11).
LCD Flex Cable	Display (page 2-10). LCD module (page 2-11).	<p>Remove the LCD flex cable from the shield.</p> <p>Reassembly Notes: Attach the cable to the shield as in the original unit. Caution: Use compatible parts (page 2-11).</p>
LCD Module	See page 2-11.	
LCD Shield (part of LCD kit)	Display (page 2-10). LCD module (page 2-11).	<p>Remove the LCD flex cable from the shield.</p> <p>Caution: Use compatible parts (page 2-11).</p>
LED Strip Cable	Display (page 2-10).	<ol style="list-style-type: none"> Remove the LCD module and brackets from the display case, but do not disassemble the module (page 2-11). If necessary to free the LED cable, remove the right LCD bracket. <p>Reassembly Notes: Make sure the LED cable is routed through the bottom-right corner of the LCD bracket.</p>
Strip Cover (Top Case)	Display (page 2-10).	Unsnap the strip cover from the hinge covers.

Table 2-9. Removing Top Case Components

Component	Removal Procedures	Additional Steps
Keyboard	See page 2-8.	
Strip Cover	Display (page 2-10).	Unsnap the strip cover from the hinge covers.
Top Case	See page 2-14.	
Touch-Pad Flex Cable	Plug-in module (page 2-3). Hard drive (page 2-5). Keyboard (page 2-8). Display (page 2-10). Top case (page 2-14).	<ol style="list-style-type: none"> 1. Remove the two screws holding the support assembly to the top case. 2. Peel off the four pads of the flex cable from the support plate. 3. Release the flex cable from the PCA. <p>Reassembly Notes: Position the four pads using the bumps on the support plate. Check the feel and operation of all four click buttons.</p> <p>Caution: Do not press on the round switches on the four pads. Press next to the switches.</p>
Touch-Pad Support Assembly	Plug-in module (page 2-3). Hard drive (page 2-5). Keyboard (page 2-8). Display (page 2-10). Top case (page 2-14).	<p>Remove the two screws holding the support assembly to the top case.</p> <p>Reassembly Notes: Check the feel and operation of all four click buttons.</p>

Table 2-10. Removing Bottom Case Components

Component	Removal Procedures	Additional Steps (See figures on pages 4-2, 4-6)
Air Vent Cover	Plug-in module (page 2-3). Hard drive (page 2-5). Keyboard (page 2-8). Display (page 2-10). Top case (page 2-14).	<ol style="list-style-type: none"> 1. Remove the screw from the plastic heat exchange cover and remove the cover. 2. Lift off the fan and move it aside. 3. Remove the screw from the heatsink cover and remove the cover. 4. Remove the screws from the CPU top plate and remove the plate. 5. Remove the screw holding the left frame to the motherboard and lift off the frame. 6. Lift out the air vent cover.
Audio Jack Cover	Plug-in module (page 2-3). Hard drive (page 2-5). Keyboard (page 2-8). Display (page 2-10). Top case (page 2-14).	<ol style="list-style-type: none"> 1. Remove the screw from the IR PCA and move the PCA aside. 2. Remove the two screws from the right frame and remove the frame. 3. Lift the front-right corner of the motherboard slightly and remove the audio jack cover.
Audio Jack PCA	Plug-in module (page 2-3). Hard drive (page 2-5). Keyboard (page 2-8). Display (page 2-10). Top case (page 2-14).	<ol style="list-style-type: none"> 1. Remove the screw from the IR PCA and move the PCA aside. 2. Remove the two screws from the right frame and remove the frame. 3. Unplug the DC-DC PCA. 4. Unplug the audio jack PCA.
BIOS IC	See page 2-19.	
Bottom Case	See page 2-16.	

Component	Removal Procedures	Additional Steps (See figures on pages 4-2, 4-6)
CPU Bottom Plate	Keyboard (page 2-8).	<ol style="list-style-type: none"> 1. Remove the screw from the heatsink cover and lift it off the heatpipe. 2. Remove the screws from the CPU top plate, then lift the right half of the complete CPU assembly so it unplugs from the motherboard. 3. Slide off the top plate, then remove the CPU module from the bottom plate. <p>Reassembly Notes: Assemble the CPU module, top plate, and bottom plate before installing them on the motherboard.</p> <p>Caution: Keep the CPU assembly flat while installing it. Press it down above the connectors at the right end. Otherwise, you could damage the connectors.</p>
CPU Module (MMO)	Keyboard (page 2-8).	<ol style="list-style-type: none"> 1. Remove the screw from the heatsink cover and lift it off the heatpipe. 2. Remove the screws from the CPU top plate, then lift the right half of the complete CPU assembly so it unplugs from the motherboard. 3. Slide off the top plate, then remove the CPU module from the bottom plate. <p>Reassembly Notes: Assemble the CPU module, top plate, and bottom plate before installing them on the motherboard.</p> <p>Caution: Replace the CPU module with one of the same module type—see the table on page 4-3.</p> <p>Caution: Install or replace CPU module thermal pads that are missing or damaged—see the picture on page 2-19.</p> <p>Caution: Keep the CPU assembly flat while installing it. Press it down above the connectors at the right end. Otherwise, you could damage the connectors.</p>
CPU Top Plate	Keyboard (page 2-8).	<ol style="list-style-type: none"> 1. Remove the screw from the heatsink cover and lift it off the heatpipe. 2. Remove the screws from the CPU top plate and remove the top plate. <p>Caution: Replace the top plate with one that is compatible with the CPU module—see the table on page 4-3.</p>
DC-DC PCA	Plug-in module (page 2-3). Hard drive (page 2-5). Keyboard (page 2-8). Display (page 2-10). Top case (page 2-14).	<ol style="list-style-type: none"> 1. Remove the screw from the IR PCA and move the PCA aside. 2. Remove the two screws from the right frame and remove the frame. 3. Unplug the DC-DC PCA.
Fan	Keyboard (page 2-8). Display (page 2-10).	<ol style="list-style-type: none"> 1. Remove the screw from the plastic cover and remove the cover. 2. Unplug the fan cable from the motherboard and lift out the fan. <p>Reassembly Notes: Route the fan wires at the bottom of the opening next to the motherboard.</p>

Component	Removal Procedures	Additional Steps (See figures on pages 4-2, 4-6)
Frame, Left	Plug-in module (page 2-3). Hard drive (page 2-5). Keyboard (page 2-8). Display (page 2-10). Top case (page 2-14).	<ol style="list-style-type: none"> 1. Remove the screw holding the heat exchange cover to the frame and remove the cover. 2. Lift off the fan and move it aside. 3. Remove the screw from the heatsink cover and remove the cover. 4. Remove the screws from the CPU top plate and remove the top plate. 5. Remove the screw holding the frame to the motherboard and remove the frame.
Frame, Left or Right	Plug-in module (page 2-3). Hard drive (page 2-5). Keyboard (page 2-8). Display (page 2-10). Top case (page 2-14).	<ol style="list-style-type: none"> 1. Remove the screw holding the IR PCA to the frame and move the PCA aside. 2. Remove the two screws holding the frame and remove the frame.
Heatsink Parts	Keyboard (page 2-8). Display (page 2-10).	<ul style="list-style-type: none"> • Heat exchange cover: Remove the screw from the plastic cover and remove it from the frame. • Heatsink cover: Remove the screw from the cover and remove it from the heatpipe. • Finned heatsink: Remove the top case (page 2-14). Remove the screw holding the heat exchange cover to the frame and remove the cover. Lift off the fan and move it aside. Remove the screw and heatsink cover, then remove the screws from the CPU top plate and remove the top plate. Remove the screw from the left frame and lift off the frame. Then lift out the finned heatsink.
IR PCA	Display (page 2-10).	Remove the screw from the IR PCA, then unplug the cable from the motherboard.
LVDS PCA	Keyboard (page 2-8). Display (page 2-10).	Use a probe to unplug the LVDS PCA from the VGA PCA. Caution: The LVDS PCA must be compatible with the LCD module. See the compatibility table on page 2-11.
Module Latch, Left	Plug-in module (page 2-3). Hard drive (page 2-5). Keyboard (page 2-8). Display (page 2-10). Top case (page 2-14).	<ol style="list-style-type: none"> 1. Remove the screw holding the heat exchange cover to the frame and remove the cover. 2. Lift off the fan and move it aside. 3. Remove the screw from the heatsink cover and remove the cover. 4. Remove the screws from the CPU top plate and remove the top plate. 5. Remove the screw holding the frame to the motherboard and remove the frame. 6. Lift off the latch and spring. <p>Reassembly Notes: See the picture on page 2-19.</p>
Module Latch, Right	Plug-in module (page 2-3). Hard drive (page 2-5). Keyboard (page 2-8). Display (page 2-10). Top case (page 2-14).	<ol style="list-style-type: none"> 1. Remove the screw from the IR PCA and move the PCA aside. 2. Remove the two screws from the right frame and remove the frame. 3. Lift off the latch and spring. <p>Reassembly Notes: See the picture on page 2-19.</p>
Motherboard	See page 2-16.	
PCMCIA Socket	Keyboard (page 2-8).	Remove the four screws from the PCMCIA socket and unplug it from the motherboard.

Component	Removal Procedures	Additional Steps (See figures on pages 4-2, 4-6)
Speaker, Left	Plug-in module (page 2-3). Hard drive (page 2-5). Keyboard (page 2-8). Display (page 2-10). Top case (page 2-14).	<ol style="list-style-type: none"> 1. Remove the screw holding the heat exchange cover to the frame and remove the cover. 2. Lift off the fan and move it aside. 3. Remove the screw from the heatsink cover and remove the cover. 4. Remove the screws from the CPU top plate and remove the top plate. 5. Remove the screw holding the frame to the motherboard and remove the frame. 6. Unplug the speaker wires and remove the speaker.
Speaker, Right	Plug-in module (page 2-3). Hard drive (page 2-5). Keyboard (page 2-8). Display (page 2-10). Top case (page 2-14).	<ol style="list-style-type: none"> 1. Remove the screw from the IR PCA and move the PCA aside. 2. Remove the two screws from the right frame and remove the frame. 3. Unplug the DC-DC PCA. 4. Unplug the speaker wires and remove the speaker.
Speaker Cover		<p>On the front corner of the case, slide the latch forward. Then slide the speaker cover forward slightly, swing it outward about 2 cm, then pull firmly until it unsnaps from the case.</p> <p>Reassembly Notes: If the slider came off the latch, attach it to the latch before you install the cover.</p>
VGA PCA	Keyboard (page 2-8). Display (page 2-10).	<ol style="list-style-type: none"> 1. Unplug the touch-pad cable from the VGA PCA. 2. Use a probe to unplug the LVDS PCA from the VGA PCA. 3. On the back of the unit, remove the two standoffs from the VGA connector. 4. Unplug the VGA PCA from the motherboard.

Troubleshooting and Diagnostics

This chapter includes troubleshooting and diagnostic information for testing the functionality of the OmniBook and identifying faulty modules:

- Troubleshooting information
 - Troubleshooting the problem (page 3-2).
 - Verifying the repair (page 3-3).
 - Suggestions for troubleshooting (page 3-4).
- Diagnostic tools
 - OmniBook hardware diagnostic program (page 3-12).
 - Power-on self-test (page 3-17).
 - Sycard PCCtest 450 PC Card (page 3-20).
 - Desktop Management Interface (page 3-21).
 - BIOS Setup utility (page 3-23).

Troubleshooting

The suggestions in this section can help isolate and repair the cause of a problem. To ensure quality repair, HP recommends that you follow the basic troubleshooting steps shown in the illustration below.

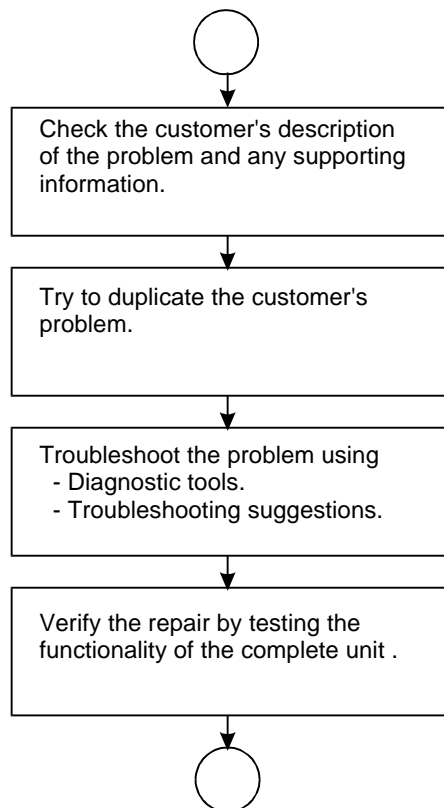

Figure 3-1. Basic Troubleshooting Steps

Troubleshooting the Problem

Record pertinent information about the unit:

- Model and serial number.
- Operating system and version.
- BIOS version.
- Accessories and peripherals used.

Analyze the problem:

- **Observe Symptoms.** Using the customer's information, try to duplicate the problem. Determine how the problem differs from proper behavior. Also, take note of the functions that *do* work properly.

- **Separate Problems.** If there is more than one symptom, separate them into distinct problems.
- **Consider Causes.** Keep in mind possible causes for each problem. Use the diagnostic tools and troubleshooting suggestions to help find possible causes.
 - The OmniBook diagnostic program is the primary troubleshooting tool—it tests most components using automatic and interactive tests. The table on page 3-4 shows how you can use the different diagnostic tools to isolate the cause.
 - The troubleshooting suggestions on page 3-5 include general suggestions for repairing units with certain failure symptoms.

Swapping easily replaced modules with known-good modules is an ideal way to isolate the cause down to the module level. It is rare for more than one module to be responsible for one failure symptom. Therefore, replacement of more than one module for a particular symptom should be the exception rather than the normal expectation.

After replacing a module, it is normal for the unit to be in a confused state and lock up when power is applied. If this occurs, press the system-off button to restart the computer in a known state.

Verifying the Repair

Before returning the repaired unit to the customer, verify the repair by running the following tests:

- **Basic Diagnostic Test.** Run the basic test of the OmniBook diagnostic program (page 3-12).
–and–
- **Function Tests.** Run tests that check the repaired function, such as in the OmniBook diagnostic program (page 3-12).
–and–
- **Failed Tests.** Run any other tests that failed during troubleshooting.

Suggestions for Troubleshooting

Table 3-1. Scope of Diagnostic Tools

Function	OmniBook Diagnostics	Power-On Self-Test	Sycard PCCtest 450	DMI/TopTools (if installed)	BIOS Setup
Bootup		Tests		Describes (SafeTools)	Configures
Processor	Tests (System menu)	Tests		Describes (AssetTools)	
Memory	Tests (Memory menu)	Tests		Describes (AssetTools)	Describes
Batteries				Describes (AssetTools)	
Display	Tests (Video, Mem, User menus)			Describes (AssetTools)	
Hard disk	Tests (IDE menu)	Tests		Describes (AssetTools)	Configures
Floppy drive	Tests (FDD menu)	Tests		Describes (AssetTools)	Describes
Keyboard	Tests (KBD menu)	Tests		Describes (AssetTools)	
Pointer	Tests (Misc menu)			Describes (AssetTools)	Configures
Audio	Tests (System, Misc menus)				Configures
Serial	Tests* (Misc menu)			Describes (AssetTools)	Configures
Parallel	Tests* (Misc menu)			Describes (AssetTools)	Configures
Infrared	Tests† (Misc menu)			Describes (AssetTools)	Configures
PS/2 port	Tests† (KBD, Misc menus)				
USB	Tests† (System menu)			Describes (AssetTools)	
Docking port	Tests (using docks)				
PCMCIA			Tests	Describes (AssetTools)	
AC adapter				Status (AssetTools)	
Docking products	Tests ports and internal bus			Status (AssetTools)	Configures
CD-ROM drive	Tests (IDE menu)	Tests (with boot CD)		Describes (AssetTools)	Configures
Other plug-in modules				Describes (AssetTools)	

* The diagnostic test is more thorough if you use a loopback connector.

† Use an appropriate external device to exercise the port. See the help text for the tests in the menu.

If you can't isolate the cause of a problem using the diagnostic tools, you can use the suggestions in the following table to help find the problem.

Table 3-2. Troubleshooting Suggestions

Symptom	Call Center: Suggestions	Repair Center: Likely Causes	Repair Center: Comments
To help determine likely causes, check to see what replaceable modules are involved in the system function and what roles they play. See the table on page 1-13.			
Startup			
Does not boot on ac or battery	Check the power source. Push system-off button. Unplug the ac adapter and remove all batteries, then reconnect power. Remove any RAM board and try again. Reinsert and try again.	AC adapter. DC-DC PCA. RAM board. CPU module. Motherboard. VGA PCA. LCD module. Hard drive.	Check ac adapter. Remove any RAM boards and retry. If power status light does not turn on, reprogram BIOS, replace DC-DC PCA, replace motherboard. If power status light turns on but display remains off, try external monitor. If monitor shows successful boot, replace LCD module. If monitor shows activity but BIOS does not complete, replace CPU module. If monitor is blank, replace VGA PCA, replace CPU module, replace motherboard. If power status light and display turn on, BIOS completes, but OS does not start from hard disk or from floppy drive, replace CPU module, then motherboard. If OS starts from floppy drive, reload hard drive, replace hard drive.
Does not boot on battery (boots on ac)	Check battery level on battery LEDs. Check battery contacts. If available, try another battery.	Battery or contacts. DC-DC PCA. Motherboard.	
Does not boot from floppy drive	Check floppy drive contacts. Try using alternate connection (with or without floppy cable). Check boot order in BIOS Setup. Check that floppy boot is enabled in BIOS Setup.	Floppy drive or contacts. Floppy cable. Motherboard.	
Error message such as "Invalid system disk" or "Auto IDE error"	Check for a disk in floppy drive. Remove and reinsert hard drive. Check boot order in BIOS Setup.	Hard drive contacts. Hard drive.	If unit boots from floppy drive, check for corrupt files on hard drive, reload hard drive, replace hard drive.

Symptom	Call Center: Suggestions	Repair Center: Likely Causes	Repair Center: Comments
Sluggish startup or shutdown	Run ScanDisk and Disk Defragmenter to check and optimize the hard drive. Delete temporary and unneeded files.		Use same suggestions shown at left.
Password has been forgotten	Verify proper ownership, then follow the removal procedure with the owner and log the appropriate data—see page 5-1.		The user must call Technical Support and provide proof of ownership. Password removal is restricted to certain sites. See page 5-1.
Power/Battery			
Short battery operating time	Turn down display brightness. Check power management settings in BIOS Setup. Try the default settings. Inform user that certain applications can cause excess power usage. (User can get power monitor from www.intel.com and monitor CPU load.) Heavy modem use can affect battery operating time.	Battery. Motherboard.	Battery capacity often decreases after a year or more.
Does not run on battery, empty battery indication	Check battery contacts. If available, try another battery.	Battery or contacts. Motherboard.	
Battery does not charge	Check the power source. Check battery contacts. If available, try another battery and ac adapter. Check for high ambient temperature and blocked air vents.	Battery or contacts. AC adapter. Motherboard. Fan. DC-DC PCA.	Check ac adapter. Check fan.
Second battery does not work, main battery works	Try swapping the two batteries. Check contacts on second battery. Second battery does not charge until main battery is fully charged.	Second battery or contacts. Motherboard.	
Battery indicator is inaccurate	Completely charge and discharge the battery 2 to 4 cycles in the unit.	Motherboard.	Try cycling the battery charge.
Display			
Dark display, no light	Adjust display brightness. Press Fn+F5 several times. Try external monitor.	LCD module (backlight). LCD cable or connections. Inverter PCA. LVDS PCA.	If an external monitor displays no image, replace the VGA PCA instead, then motherboard.
White display	Adjust display brightness.	LCD module. Inverter PCA. LVDS PCA.	

Symptom	Call Center: Suggestions	Repair Center: Likely Causes	Repair Center: Comments
Erratic display		LCD cable or connections. LCD module.	
Bright or missing pixels or lines	See quality statement on page 5-2.	LCD module. LCD cable or connections.	See quality statement on page 5-2.
Hard disk			
Hard disk never spins	Check the power source. Remove and reinsert the hard drive. Check the contacts.	Hard drive or contacts. Motherboard. Hard drive case (flex cable).	If the drive case is damaged, it can prevent proper operation.
Hard disk makes clunking or scratching noise	Back up the drive immediately. Was the computer or drive dropped?	Hard drive.	Check the computer and drive for evidence of customer abuse.
Hard disk makes buzzing or whining noise	Back up the drive immediately. Check for alternate noise sources, such as a PCMCIA drive or fan. If a keystroke causes the sound to change, it may be power supply noise.	Depends on the source of the noise.	
Files are corrupted	Run a virus scan program. Check the disk surface by running Scandisk (Windows 95) or Disk Administrator (Windows NT). Or boot to DOS and run CHKDSK to look for problems, run CHKDSK /f to fix. Use Recovery CD to restore original factory software.		Use same suggestions shown at left.
Drive capacity is less than normal	Check the disk surface by running Scandisk (Windows 95) or Disk Administrator (Windows NT). Check partitions using FDISK (Windows 95) or Disk Administrator (Windows NT).	Hard drive.	Use same suggestions shown at left. Recreate the Hibernate partition, then partition and format the disk.
Floppy drive			
General problems	Check floppy module contacts. Try using alternate connection (with or without floppy cable). Check settings in BIOS Setup.	Floppy module or contacts. Floppy cable. Motherboard.	
Keyboard			
Some or all keys do not work properly		Keyboard. Motherboard. BIOS IC.	

Symptom	Call Center: Suggestions	Repair Center: Likely Causes	Repair Center: Comments
PS/2 keyboard and mouse with Y-adapter do not work	Check devices separately.	Y-adapter. PS/2 device. Motherboard.	
Pointing stick			
General problems	Check settings in Control Panel. Check that the pointing stick is enabled in BIOS Setup.	Keyboard assembly. Motherboard.	
Special TrackPoint driver features not working	If installed, remove TouchPad driver support using Add/Remove Program. In Mouse Properties, select the IBM TrackPoint driver from the track-point directory under \OmniBook\Drivers.	Keyboard assembly. Motherboard.	
Click button doesn't work		Touch-pad support (flex cable). Motherboard.	
Touch pad			
General problems	Check settings in Control Panel. Check pointing stick settings in Control Panel. The IBM TrackPoint driver can redefine touch pad operation. Check that the touch pad is not disabled in BIOS Setup.	Touch-pad support (PCA or flex cable). Motherboard.	
Special TouchPad driver features not working	If installed, remove IBM TrackPoint support using Add/Remove Program, then in Mouse Properties, select the standard PS/2 mouse. Disable the pointing stick in BIOS Setup. Run Setup.exe from the touch-pad subdirectory under \OmniBook\Drivers.	Touch-pad support (PCA or flex cable). Motherboard.	
Click button doesn't work		Touch-pad support (flex cable). Motherboard.	
Audio			
Sound does not play	Check settings in BIOS Setup. Increase sound volume (Fn+UP and software controls). Check whether mute is active (mute button and software controls). Check for sound resource conflicts.	Speakers. Motherboard.	Check operation using headphones or external speakers (audio jack PCA).

Symptom	Call Center: Suggestions	Repair Center: Likely Causes	Repair Center: Comments
Sound does not record	Check settings in BIOS Setup. Check software controls for microphone—it should not be muted in recording panel. Note: The microphone should normally be muted in the master output panel.	Inverter PCA (mic). Motherboard.	Check operation using external microphone (audio jack PCA).
Serial/Parallel			
General problems	Check settings in BIOS Setup. Check settings in Control Panel (and in Windows NT Diagnostics).	Motherboard.	
Infrared			
General problems	Infrared communication is not supported in Windows NT 4.0. Infrared is disabled and no drivers installed as shipped. (Drivers are included.) Check settings in BIOS Setup. Standard IrDA and fast-IrDA are incompatible (they use different drivers). For fast-IrDA, check for DMA conflict with ECP parallel port.	IR PCA. Motherboard.	
USB			
General problems	USB is not supported in Windows NT 4.0.	Motherboard.	
PCMCIA			
Setup problems	Make sure Card Executive is installed for Windows NT. If the card requires an IRQ, check that there is one available. Check for conflicts or refresh the device list in Device Manager (Windows 95) or Administrative Tools or Control Panel System (Windows NT). Reboot the computer. Try the card in the other slot or in another computer. Check the OmniBook website for installation instructions (page vi). Download current drivers from the card manufacturer's website.	Motherboard. PCMCIA socket.	If both slots have problems, replace the motherboard. If only one slot has a problem, try replacing the PCMCIA socket.

Symptom	Call Center: Suggestions	Repair Center: Likely Causes	Repair Center: Comments
AC adapter			
Does not power the OmniBook	Try another ac adapter, if available.	AC adapter. DC-DC PCA. Motherboard.	The ac adapter is not repairable—it must be replaced.
Miscellaneous			
Clock loses time	Plug in ac adapter for 24 hours to charge backup battery.	Motherboard.	Charge backup battery.
Computer gets hot	It is normal for the computer to get hot. Make sure the air vents are clear. DOS games and other programs that drive CPU usage toward 100% can contribute.	Fan. Thermal connections. Heatsink damage.	Check the fan. Check for proper contact between CPU and its top plate, and between heatpipe and heatsink.
Computer pauses or runs sluggishly	May be normal Windows behavior (background processing can affect response time). If the hard disk has spun down to conserve power, it can take several seconds to spin up. You can hear this. You can run BIOS Setup and change the hard disk time-out to match the Suspend time-out. Certain background operations (such as HP COE virus scans) can affect performance while they're running. Some file browsers may be unresponsive while they're processing a graphic image or waiting for broken network connections to time out. Run BIOS Setup and try turning off smart CPU mode.	CPU module. Motherboard.	If computer slows after a period of continuous activity, check thermal connections and parts.
Accessories			
Docking product I/O problems	Check that ac power is connected. Check settings in BIOS Setup. Try using the corresponding OmniBook port.	Docking product. Motherboard.	Test the corresponding OmniBook ports while undocked. The port replicator and mini dock are not repairable—they must be exchanged. The docking system is repairable—see its service manual.
Can not boot from CD in CD-ROM drive	Check that the CD is bootable. Check ESC key timing during boot, or check boot order in BIOS Setup.	CD-ROM drive.	The CD-ROM drive is not repairable—it must be exchanged.

Symptom	Call Center: Suggestions	Repair Center: Likely Causes	Repair Center: Comments
General plug-in module problems	Check module contacts. Push system-off button.	Plug-in module or contacts. Motherboard.	Plug-in modules are not repairable—they must be exchanged.

Diagnostic Tools

This section describes the following diagnostic tools you can use for troubleshooting and repairing the OmniBook:

- OmniBook hardware diagnostic program (below).
- Power-on self-test (page 3-17).
- Sycard PCCtest 450 PC Card (page 3-20).
- Desktop Management Interface (page 3-21).
- BIOS Setup utility (page 3-23).

OmniBook Diagnostic Program

The OmniBook hardware diagnostic program provides two levels of testing:

- User-level testing using the basic hardware test.
- Advanced testing using the individual hardware tests.

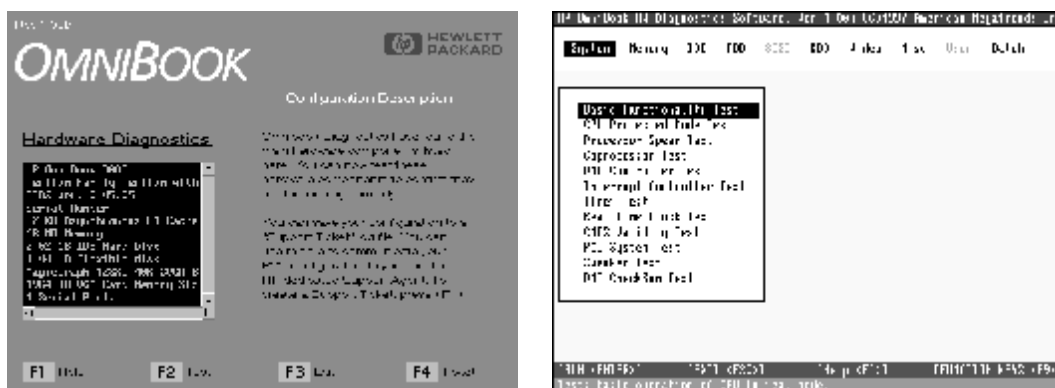

Figure 3-2. OmniBook Diagnostic Screens — Basic and Advanced

The tests are designed to run after the system reboots. This ensures that the computer will be in a predictable state, so the diagnostic program can properly test the hardware components. The tests are non-destructive and are intended to preserve the state of the computer. The OmniBook reboots when you exit the program so drivers can be loaded.

Creating a Diagnostic Floppy Disk

After inserting a formatted floppy disk in the floppy drive, do one of the following to create a diagnostic floppy disk:

- On an OmniBook with a factory software installation, run **diaginst** from the \Dmi\Hpdiags directory on the hard disk.
—or—
If TopTools is installed, use the DiagTools page to create the disk.
- On any computer with a CD-ROM drive, run **diaginst** from the \Omniobook\Dmi\Hpdiags directory on the OmniBook 4100 Recovery CD.

- On any computer with World Wide Web access, download the diagnostic software package from the OmniBook website (see page vi), run this file to unpack the files, then run **diaginst** to create the diagnostic disk.

Running the Diagnostic Test

1. Insert the diagnostic disk in the floppy drive.
2. Reboot the OmniBook.
3. Go through the first several screens.
4. When the hardware detection finishes, check the list of detected hardware. The following information and devices should be listed if applicable:

Product name	Main memory	Graphics adapter
Processor type	IDE drives	Serial ports
BIOS version	Floppy drives	Parallel port
Serial number	Keyboard	Audio device
Cache memory		

Note

If a device is not detected or fails its test below, it may be configured incorrectly in the BIOS Setup utility (page 3-23). You can confirm the problem by running BIOS Setup and checking the settings.

5. **Run the basic test.** Press F2 to start the basic hardware test.
6. If you intend to exit without running advanced tests, press F4 to save system and test information in the Support Ticket log file, HPSUPPT.TXT. Then remove the diagnostic disk and press F3 to exit.
7. **Run the advanced tests.** Press F2 to open the advanced test screen.
8. Select and run the appropriate tests. Tests are not listed if no such hardware is detected. Press the following keys to run tests:

ENTER	Runs the highlighted test.
F5 or SPACE	Marks or unmarks the highlighted test.
F6	Marks or unmarks all tests in the current menu.
F7	Marks or unmarks all tests in all menus.
F10	Runs all marked tests.

If any test fails, the error is logged (error code and description) and displayed temporarily (error code). If several errors occur, look for patterns that might indicate a common cause. See the table on page 3-14 for repair suggestions. Consider these suggestions in combination with other troubleshooting information.
9. When you are finished running tests, press ESC to exit the advanced tests.
10. Press F4 to save system and test information in the Support Ticket log file, HPSUPPT.TXT.
11. **Exit.** Press F3 to exit and reboot.
12. **Optional: Check the log.** On any computer, open the HPSUPPT.TXT log file on the diagnostic disk using Notepad or other text editor. It contains a hardware summary and a list of all test results and errors.

Note that the serial and parallel port tests are more thorough if you connect a loopback connector to the port before running the test for that port. See the wiring diagrams below.

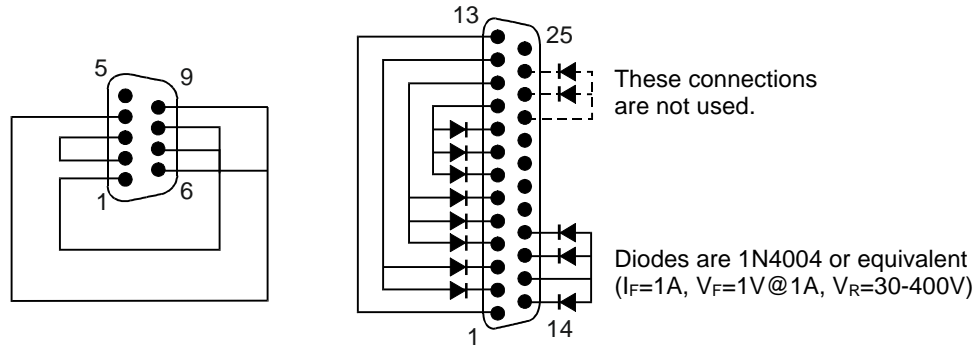

Figure 3-3. Serial and Parallel Loopback Connectors

Interpreting the Results

- The following table lists test groups, error codes, and suggestions for followup actions. Consider these suggestions in combination with other troubleshooting information.

Table 3-3. OmniBook Diagnostic Error Codes

Code	Suggestions
System Tests	
0001h - 0008h	Reseat or replace the CPU module.
0009h	Replace the motherboard.
0010h - 002Fh	Reseat or replace the CPU module.
0030h - 0040h	Replace the motherboard.
0041h	Unrecognized interrupts. Run BIOS Setup and check IRQ assignments for all devices.
0050h - 0070h	Replace the motherboard.
0071h	Bad CMOS checksum. Reset the system, then run BIOS Setup and check settings. Replace motherboard.
0072h	Configuration mismatch in CMOS. Reset the system, then run BIOS Setup and check settings. Replace motherboard.
0073h	Bad CMOS RAM size. Reset the system, then run BIOS Setup and check settings. Replace motherboard.
0074h	Bad CMOS time. Reset the system, then run BIOS Setup and check settings. Replace motherboard.
0075h - 0076h	Reset the system. Replace the motherboard.
0077h	Replace the motherboard.
0078h	Bad CMOS checksum. Reset the system, then run BIOS Setup and check settings. Replace motherboard.
0079h	Replace the motherboard.
0083h - 0086h	Replace the BIOS IC. Replace the motherboard.
0087h	Replace the motherboard.
0088h	Replace the BIOS IC.
0090h - 0096h	Replace the BIOS IC. Replace the motherboard.
009Ah - 009Eh	Replace the BIOS IC. Replace the motherboard.
009Fh	Insufficient DOS memory. Load fewer device drivers.
00A0h	No repair. (ESCD not supported.)
00A1h	Replace the BIOS IC. Replace the motherboard.
00A2h - 00A3h	No repair. (ESCD not supported.)
00A4h	Replace the BIOS IC.
00A5h - 00A6h	No repair. (ESCD not supported.)
00A7h	Replace the BIOS IC. Replace the motherboard.
00FFh	Rerun the test. (Possible diagnostic programming error.)
Memory Tests	
The addresses below are absolute (32-bit) address. These addresses are not in the segment:offset format.	
0100h - 0101h	Replace the motherboard.
0102h	Replace the BIOS IC.
0120h - 0150h	For 01FFFFFFh and below, replace the motherboard. For 02000000h and above, replace the RAM board (each 01000000h represents 16MB).
0160h	Address bus short. Remove any RAM board and rerun the test. Check the CPU module for shorts. Replace the motherboard.
0170h - 0172h	Replace the motherboard.
0180h	For 01FFFFFFh and below, replace the motherboard. For 02000000h and above, replace the RAM board (each 01000000h represents 16MB).

0181h	Replace the CPU module.
0182h	Make sure that another application is not using all extended memory allocated by HIMEM.SYS.
0183h	No extended memory. Check installation of the RAM board. Replace the motherboard.
0190h - 01A0h	For 01FFFFFFh and below, replace the motherboard. For 02000000h and above, replace the RAM board (each 01000000h represents 16MB).
Hard Disk Tests	
0201h	Replace the hard disk. Replace the motherboard.
0202h - 0204h	Rerun the test. If error persists, replace the hard disk.
0205h	Replace the motherboard.
0207h	Run BIOS Setup and check the hard disk type. Check internal and external hard disk connectors and motherboard connector. Replace the hard disk.
0208h - 0209h	Transient DMA error. Rerun the test.
020Ah - 0211h	Rerun the test. Run SCANDISK or equivalent.
0220h	Replace the motherboard.
0240h	Replace the hard disk. Replace the motherboard.
0280h	Check internal and external hard disk connectors and motherboard connector. Replace the hard disk.
0281h	Replace the hard disk.
02AAh	Check internal and external hard disk connectors and motherboard connector. Replace the hard disk.
02CCh	Run BIOS Setup and check the hard disk type. Replace the hard disk or the motherboard.
02EEh	For the performance test, run BIOS Setup and temporarily select a drive type that has more than 200 cylinders.
02F1h	Recreate the Hibernate partition, then run FDISK to partition the hard disk.
02F2h	Run FDISK to make one partition active. If necessary, recreate the Hibernate partition, then run FDISK to partition the hard disk.
02F3h	Run FDISK to check for overlapping partitions. If necessary, recreate the Hibernate partition, then run FDISK to partition the hard disk.
02F4h	Check for the presence of a boot sector virus. If necessary, recreate the Hibernate partition, then run FDISK to partition the hard disk.
02F5h	Reformat the partition.
02F6h	Recreate the Hibernate partition, then run FDISK to partition the hard disk.
02FFh	Check internal and external hard disk connectors and motherboard connector. Replace the hard disk. Replace the motherboard.
Floppy Disk Tests	
0301h	Replace the floppy drive. Replace the motherboard.

0302h	Run BIOS Setup and check the floppy drive type. Replace the floppy drive.
0303h	Insert a floppy disk without write protection.
0304h	Run BIOS Setup and check the floppy drive type. Replace the floppy drive.
0305h	Replace the motherboard.
0307h	Run BIOS Setup and check the floppy drive type. Check the connectors on the floppy drive and motherboard. Replace the floppy drive.
0308h - 0309h	Transient DMA error. Rerun the test.
030Ah - 0310h	Rerun the test with a good floppy disk. Replace the floppy drive.
0311h	Rerun the test with another floppy disk.
0321h - 0322h	Replace the floppy drive.
0340h	Replace the motherboard.
0380h - 03AAh	Make sure the floppy disk is fully inserted. Check the connectors on the floppy drive and motherboard. Replace the floppy drive.
03CCh	Run BIOS Setup and check the floppy drive type. Rerun the test with another floppy disk. Replace the floppy drive. Replace the motherboard.
03EEh - 03FFh	Check the connectors on the floppy drive and motherboard. Rerun the test with another floppy disk. Replace the floppy drive. Replace the motherboard.
Keyboard Tests	
0400h - 0401h	Replace the motherboard.
0410h - 0414h	Check the keyboard flex cable connection. Replace the keyboard. Replace the motherboard.
0415h	Replace the VGA PCA. Replace the motherboard.
0416h - 0418h	Replace the keyboard. Replace the motherboard.
Serial Port Tests	
0601h	For the external loopback test, make sure the loopback connector is installed and constructed properly. For the external or internal loopback test, replace the motherboard.
0602h	Replace the motherboard.
0603h	For the external loopback test, make sure the loopback connector is installed and constructed properly. For the external or internal loopback test, replace the motherboard.
0604h - 0605h	Replace the motherboard.
0606h	For the external loopback test, make sure the loopback connector is installed and constructed properly. For the external or internal loopback test, replace the motherboard.
0607h	Make sure the loopback connector is installed and constructed properly. Replace the motherboard.
0608h - 0611h	Replace the motherboard.

Parallel Port Tests	
0701h	For the external loopback test, make sure the loopback connector is installed and constructed properly. For the external or internal loopback test, replace the motherboard.
0702h	Replace the motherboard.
0703h	Run BIOS Setup and disable ECP for the parallel port, then rerun the test. Replace the motherboard.
0704h - 0706h	Replace the motherboard.
0707h	Connect the loopback connector.
0708h	Replace the motherboard.
Audio Tests	
0801h - 0812h	If this error also occurs for an external headphone, replace the motherboard. Otherwise, check the speaker connections, replace the speakers. If it occurs only for an external headphone, replace the audio jack PCA.
9003h - 9004h	(See Microphone Tests near end of table.)
Video Tests	
0900h - 0901h	Replace the VGA PCA.
0903h - 0906h	Replace the LVDS PCA. Replace the VGA PCA.
0907h - 0908h	Replace the VGA PCA.
0909h - 090Ah	Replace the LVDS PCA. Replace the VGA PCA.
090Ch - 090Fh	Replace the VGA PCA.
8000h	(See LCD Test near end of table.)
CD-ROM Tests	
0A00h	Insert a CD in the drive.
0A01h	Rerun the test. Replace the CD-ROM drive.
0A02h	No repair. (Automatic close not supported.)
0A03h	Insert a different CD in the drive. Check the connectors on the CD-ROM drive and motherboard. Replace the CD-ROM drive.
0A04h	Insert a different CD in the drive. Check the connectors on the CD-ROM drive and motherboard. Replace the CD-ROM drive.
0A05h	Insert a computer CD in the drive.
0A06h	Insert an audio CD in the drive.
USB Tests	
1301h	Reprogram the BIOS IC. Replace the BIOS IC. Replace the motherboard.

1302h - 1306h	Replace the motherboard.
9006h	(See USB Port Test near end of table.)
LCD Test	
8000h	If the test fails with an external monitor (must support VESA mode 105h), replace the VGA PCA, replace the motherboard. Otherwise: - If the shaded-band test fails, check the LCD flex cable connection in the bottom case, replace the LVDS PCA, replace the LCD flex cable, replace the VGA PCA, replace the motherboard. - If only a solid-color test fails, see chapter 5 for cosmetic guidelines, replace the LCD module.
Microphone/Line-In Tests	
9003h	If the error occurs for built-in and external microphones, replace the motherboard. If it occurs for only the built-in microphone, check the LCD flex cable connection, replace the inverter PCA. If it occurs only for an external microphone, replace the audio jack PCA.
9004h	Replace the audio jack PCA. Replace the motherboard.
Suspend/Resume Test	
9005h	Run BIOS Setup and restore default settings. Reprogram the BIOS IC. Replace the BIOS IC. Replace the motherboard.
USB Port Test	
9006h	Make sure a USB device is connected to the port you are testing. Select the correct speed for the device. Replace the motherboard (or dock component, if applicable).
IR Tests (FIR enabled, undocked)	
9002h, 9007h - 9008h	Rerun the test. Replace the motherboard.
9009h	Do not run this test in Windows. For the one-unit test, replace the motherboard. For the two-unit test, make sure the IR ports on the reflector and test computers are lined up, replace the IR PCA, replace the motherboard.
900Ah	Rerun the test. For the two-unit test, make sure the IR ports on the reflector and test computers are lined up. Replace the IR PCA, replace the motherboard.
900Ch	Rerun the test. Make sure the IR ports on the reflector and test computers are lined up. Restart the reflector unit. Replace the IR PCA, replace the motherboard.

Power-On Self-Test

Note

If Quiet Boot is enabled in BIOS Setup (the default setting), press ESC during boot to see POST messages.

The POST (Power-On Self-Test) is a series of initialization routines and diagnostic tests that the system BIOS runs when the computer boots. The system BIOS will not boot the operating system if system memory, the CPU, DMA, or the interrupt controller fails the POST diagnostic tests. POST progress is indicated by a sequence of codes. If possible, error messages are displayed.

You should not interpret the failure of one or more POST tests as a hardware, software, or firmware failure. First, confirm the failure with a “clean” boot:

- Remove all accessories, including RAM boards, floppy drive, port replicator, PC Cards, printer, external monitor, pointing device, and keyboard.
- Provide “clean” ac power—no auto adapter or unusual ac adapter configuration.
- Press the system-off button to start from a known state.

If the computer fails to boot with a clean boot, it requires repair. If an error message is displayed, *confirm the problem using other diagnostic tools*. Not all POST messages indicate a hardware, software, or firmware failure—some messages are informational messages.

If the BIOS detects a terminal error condition, it halts POST after issuing a terminal error beep code—up to four groups of 1 to 4 short beeps. The beep code indicates the POST routine in which the terminal error occurred. The BIOS also issues a beep code (one long tone followed by two short tones) during POST if the video configuration fails (no card installed or faulty) or if an external ROM module does not properly checksum to zero.

Table 3-4. POST Terminal-Error Beep Codes

Beep Codes	POST Description
1	One short beep before boot
1-2	Search for option ROMs. One long, two short beeps on checksum failure
1-2-2-3	BIOS ROM checksum
1-3-1-1	Test DRAM refresh
1-3-1-3	Test 8742 Keyboard Controller
1-3-4-1	RAM failure on address line xxxx
1-3-4-3	RAM failure on data bits xxxx of low byte of memory bus
1-4-1-1	RAM failure on data bits xxxx of high byte of memory bus
2-1-2-3	Check ROM copyright notice
2-2-3-1	Test for unexpected interrupts

The following table lists POST messages and explanations for reported problems. If the system fails after you make changes in BIOS Setup, reset the computer, enter BIOS Setup, and install the defaults or correct the error.

Table 3-5. POST Messages

Message	Description
0200 Failure Fixed Disk	Fixed disk is not working or not configured properly. Check to see if fixed disk is attached properly. Run Setup. Find out if the fixed-disk type is correctly identified.
0210 Stuck key	Stuck key on keyboard.
0211 Keyboard error	Keyboard not working.
0212 Keyboard Controller Failed	Keyboard controller failed test. May require replacing keyboard controller.
0213 Keyboard locked - Unlock key switch	Unlock the system to proceed.
0220 Monitor type does not match CMOS - Run SETUP	Monitor type not correctly identified in Setup
0230 Shadow Ram Failed at offset: <i>nnnn</i>	Shadow RAM failed at offset <i>nnnn</i> of the 64k block at which the error was detected.
0231 System RAM Failed at offset: <i>nnnn</i>	System RAM failed at offset <i>nnnn</i> of in the 64k block at which the error was detected.
0232 Extended RAM Failed at offset: <i>nnnn</i>	Extended memory not working or not configured properly at offset <i>nnnn</i> .
0250 System battery is dead - Replace and run SETUP	The CMOS clock battery indicator shows the battery is dead. Connect the ac adapter for at least 24 hours, replace the motherboard.
0251 System CMOS checksum bad - Default configuration used	System CMOS has been corrupted or modified incorrectly, perhaps by an application program that changes data stored in CMOS. The BIOS installed Default Setup Values. If you do not want these values, enter Setup and enter your own values. If the error persists, check the system battery. Connect the ac adapter for at least 24 hours, replace the motherboard.
0260 System timer error	The timer test failed. Requires repair of system board.
0270 Real time clock error	Real-time clock fails BIOS test. May require board repair.
0280 Previous boot incomplete - Default configuration used	Previous POST did not complete successfully. POST loads default values and offers to run Setup. If the failure was caused by incorrect values and they are not corrected, the next boot will likely fail. This error is cleared the next time the system is booted.
0281 Memory Size found by POST differed from CMOS	Memory size found by POST differed from CMOS.
02B0 Diskette drive A error 02B1 Diskette drive B error	Drive A: or B: is present but fails the BIOS POST diskette tests. Check to see that the drive is defined with the proper diskette type in Setup and that the diskette drive is attached correctly.
02B2 Incorrect Drive A type - run SETUP	Type of floppy drive A: not correctly identified in Setup.
02B3 Incorrect Drive B type - run SETUP	Type of floppy drive B: not correctly identified in Setup.
02D0 System cache error - Cache disabled	RAM cache failed and BIOS disabled the cache. On older boards, check the cache jumpers. You may have to replace the cache. See your dealer. A disabled cache slows system performance considerably.
02F0: CPU ID:	CPU socket number for Multi-Processor error.
02F4: EISA CMOS not writeable	ServerBIOS2 test error: Cannot write to EISA CMOS.
02F5: DMA Test Failed	ServerBIOS2 test error: Cannot write to extended DMA (Direct Memory Access) registers.
02F6: Software NMI Failed	ServerBIOS2 test error: Cannot generate software NMI (Non-Maskable Interrupt).

Message	Description
02F7: Fail-Safe Timer NMI Failed	ServerBIOS2 test error: Fail-Safe Timer takes too long.
device Address Conflict	Address conflict for specified device.
Allocation Error for: device	Run ISA or EISA Configuration Utility to resolve resource conflict for the specified device.
CD ROM Drive	CD ROM Drive identified.
Entering SETUP ...	Starting Setup program
Failing Bits: nnnn	The hex number nnnn is a map of the bits at the RAM address which failed the memory test. Each 1 (one) in the map indicates a failed bit. See errors 230, 231, or 232 above for offset address of the failure in System, Extended, or Shadow memory.
Fixed Disk n	Fixed disk n (0-3) identified.
Invalid System Configuration Data	Problem with NVRAM (CMOS) data.
I/O device IRQ conflict	I/O device IRQ conflict error.
PS/2 Mouse Boot Summary Screen:	PS/2 Mouse installed.
nnnn kB Extended RAM Passed	Where nnnn is the amount of RAM in kilobytes successfully tested.
nnnn Cache SRAM Passed	Where nnnn is the amount of system cache in kilobytes successfully tested.
nnnn kB Shadow RAM Passed	Where nnnn is the amount of shadow RAM in kilobytes successfully tested.
nnnn kB System RAM Passed	Where nnnn is the amount of system RAM in kilobytes successfully tested.
Operating system not found	Operating system cannot be located on either drive A: or drive C:. Enter Setup and see if fixed disk and drive A: are properly identified.
Parity Check 1 nnnn	Parity error found in the system bus. BIOS attempts to locate the address and display it on the screen. If it cannot locate the address, it displays ????. Parity is a method for checking errors in binary data. A parity error indicates that some data has been corrupted.
Parity Check 2 nnnn	Parity error found in the I/O bus. BIOS attempts to locate the address and display it on the screen. If it cannot locate the address, it displays ????.
Press <F1> to resume, <F2> to Setup, <F3> for previous	Displayed after any recoverable error message. Press <F1> to start the boot process or <F2> to enter Setup and change the settings. Press <F3> to display the previous screen (usually an initialization error of an Option ROM, such as an add-on card). Write down and follow the information shown on the screen.
Press <F2> to enter Setup	Optional message displayed during POST.
PS/2 Mouse:	PS/2 mouse identified.
System BIOS shadowed	System BIOS copied to shadow RAM.
UMB upper limit segment address: nnnn	Displays the address nnnn of the upper limit of Upper Memory Blocks, indicating released segments of the BIOS which can be reclaimed by a virtual memory manager.
Video BIOS shadowed	Video BIOS copied to shadow RAM.

Sycard PCCtest 450 CardBus Card (Optional)

The PCCtest 450 CardBus Card (version 1.05) available from Sycard Technology is an optional diagnostic tool. It is the only recommended tool that tests the functionality of the PCMCIA slots. It is a Type II CardBus Card that works with compatible test software to exercise PCMCIA functions. (See the Sycard Technology website, <http://www.sycard.com>.) The PCCtest 450 product contains these components:

- PCCtest 450 CardBus Card, version 1.05.
- PCCtest 450 software disk. (Software updates are available at the Sycard Technology website, <http://www.sycard.com>.)
- Configuration headers (PC Card/16-bit and CardBus/32-bit), which attach to the card.

You will also need:

- CardBus extender card to avoid wear on the Sycard PCMCIA connector. The Sycard PCCextend 70 extender card is an example.

The Sycard PCCtest 450 provides the following tests. See the Sycard documentation for details about running the tests.

- PC Card (16-bit) test, PCT450.
Requires the PC Card configuration header. Run the test for the Texas Instruments PCI1250A socket controller (command line switch **-b65**).
- CardBus (32-bit) test, TESTCB.
Requires the CardBus configuration header. Run the test for the Texas Instrument PCI1250A socket controller (command line switches **-b65** and **-jsd000**).

Desktop Management Interface (DMI)

The Desktop Management Interface (DMI) is basically a set of rules for accessing information about a personal computer. Using DMI, an application program can determine, for example, which hardware and software components are present in a personal computer, the operating system that is being used, and the number of accessory board slots that are available. Using the DMI interface, a local or remote application program can check what hardware and software components are installed on your computer, and may be able to tell how well they are working or whether any needs replacing. All this information is stored in a special Management Information Format (MIF) file, installed on each personal computer as part of the DMI package.

Installing the DMI Package

The DMI package is included with the OmniBook, but it must be properly installed before it can be used. The following steps explain how.

To install the DMI preloaded on the hard disk:

1. Start Windows, if it is not already running.
2. Click Start, Programs, HP DMI, Setup.

To install the DMI from floppy disks or from the OmniBook 4100 Recovery CD:

1. For floppy disks, copy the DMI software from the `\omnibook\drivers\os_version\dmi` directory of either the hard disk or Recovery CD to two or more floppy disks (for example, copy the contents of the `\disk1` subdirectory to disk #1).
2. Start Windows, if it is not already running.
3. Insert disk #1 into the floppy drive, or insert the Recovery CD into the CD-ROM drive.
4. Select and run the SETUP program from floppy disk #1 or from the `\omnibook\drivers\os_version\dmi\disk1` directory on the CD.

Uninstalling the DMI Package

1. Click Start, Programs, HP DMI, Uninstall DMI.
2. Reboot the PC.

Using the DMI Interface

For a complete explanation of how to fully take advantage of DMI, the following documentation is provided with the OmniBook:

- A README.TXT file.
- A Windows online help file describing Hewlett-Packard's implementation of DMI (group and attribute definitions). Since not all Hewlett-Packard enhanced features are supported on all models, this document also describes any restrictions that apply.

Description of DMI

The Desktop Management Interface (DMI) is the result of the efforts of the Desktop Management Task Force (DMTF). This task force was founded in 1992 by a group of leading computer manufacturers, including Hewlett-Packard, to define a standard method of managing the physical and logical components of personal computers.

Hewlett-Packard has developed a number of extensions to DMI to allow the enhanced features of HP OmniBook computer to be managed with DMI, including features such as passwords and tattooing (identifying a computer using a unique string of characters).

For full details of the structure of the MIF file, including an explanation of the meaning of the fields of groups and attributes and how to write an application program that accesses this information, you can access the DMTF FTP server ftp.dmtf.org or the DMTF web pages at the <http://www.dmtf.org>.

Contents of the DMI Package

The DMI software and associated documentation is supplied either preinstalled on the OmniBook's hard disk drive or on two floppy disks. The contents of the package are the same in both cases.

Since the information accessed by the DMI software is specific to a particular computer, it must be installed on each computer separately. The DMI package included with the OmniBook can be used only with the OmniBook.

The following software is supplied with the DMI package:

- A Microsoft Windows utility, SETUP.EXE, to install and initialize the DMI software.
- A Windows utility, HP TopTools. After DMI is installed, this utility can be used to display information about the computer through the DMI.
- A Management Information Format (MIF) file. This file contains information about everything on the computer that can be controlled using DMI facilities, and is initialized during installation.
- A component code, identifying the version of MIF file to use for specific models of HP OmniBook computers.
- Windows-compatible DMTF Service Layer software, which controls access to the DMI.
- A client agent. The HP Remote DMI Agent is a DMI application and also a network server-side stream-based application. The Remote Agent is listening for Remote Application connection requests. If the main window of the Remote Agent is hidden, then no icon will appear on the screen when it is running.

The following illustration shows a representation of several components of the DMI package.

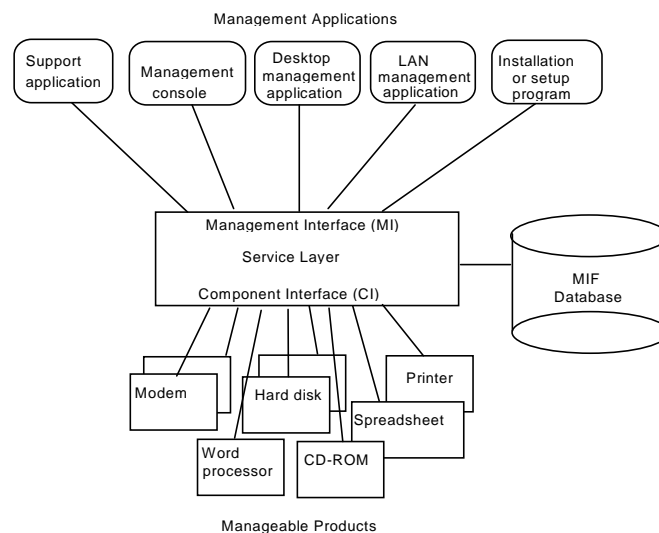

Figure 3-4. DMI Components

BIOS Setup Utility

The BIOS Setup utility provides access to basic configuration settings. It is independent of the operating system.

Running the BIOS Setup Utility

1. Close all applications, then shut down Windows and reboot the OmniBook. If necessary, you can press CTRL+ALT+DEL to reboot.
2. During reboot, press F2 to start the BIOS Setup utility.
3. The pointing device or mouse is not active in the BIOS Setup utility. Press the RIGHT and LEFT arrow keys to move among menus. Press the DOWN and UP arrow keys to move among parameters in a menu. Press ENTER to change a setting. See the table below for more information.
4. After you select the options you want, press F10 or use the Exit menu to exit the BIOS Setup utility.

If the settings cause a conflict between devices during reboot, the system prompts you to run BIOS Setup, and the conflicting settings are marked.

Table 3-6. BIOS Setup Menus and Parameters

Main Menu		Default
Language	Sets the language for this utility and BIOS messages.	English.
BIOS Revision	Shows the current BIOS version.	Detected automatically.
System Time	Sets the time using 24-hour format. Values set take effect immediately.	
System Date	Sets the date using mm/dd/yy (English) or dd/mm/yy format.	
Floppy Drive	Sets the floppy drive type.	Detected and set automatically.
Hard Disk	Sets the hard disk drive type and various parameters.	Detected and set automatically.
Quiet Boot	When enabled, hides summary of power-on self-test and messages during boot.	Enabled
Video Display Device	Sets whether the built-in and external display signals automatically switch when an external display is detected, or whether both signals are active. Pressing Fn+F5 temporarily switches displays. Setting to Both prevents suspending when lid closes.	Auto
System Memory	Shows the system memory size.	640KB
Extended Memory	Shows the extended memory size.	Detected automatically.
System Devices Menu		Default
Internal Pointing Devices	Enables one or both built-in PS/2 devices.	Both
External Fn Key	Sets whether left-CTRL + left-ALT on an external keyboard is interpreted as the Fn key.	Enabled
IDE Controller	Enables the primary (hard drive) and secondary (optional CD-ROM drive) controllers.	Both
FDD Controller	Enables the floppy drive.	Enabled
Serial Port	Sets how the serial port is configured by the BIOS (specified or automatic).	Enabled
Base I/O address	Sets the I/O address and interrupt.	3F8h, IRQ4

Infrared Port	Sets how the infrared port is configured by the BIOS (specified or automatic).	Disabled
Mode	Sets the hardware to support SIR (Standard IR), ASK IR (amplitude shift keyed IR), or FIR (Fast IR) infrared communications. (Driver installation required.)	SIR
Base I/O address	Sets the I/O address and interrupt.	2F8h, IRQ3
DMA channel	For Fast IR mode, sets the DMA channel.	DMA3
Parallel Port	Sets how the parallel port is configured by the BIOS (specified or automatic).	Enabled
Mode	Sets the port to normal, bi-directional, EPP, or ECP.	ECP
Base I/O address	Sets the I/O address.	378h
Interrupt	Sets the interrupt.	IRQ7
DMA channel	For ECP mode, sets the DMA channel.	DMA3
Audio	Sets how the audio system is configured by the BIOS (specified or automatic).	Enabled
SB I/O address	Sets the Sound Blaster I/O address.	220h
WSS I/O address	Sets the Windows Sound System I/O address.	530h
AdLib I/O address	Sets the AdLib synthesizer I/O address.	388h
Interrupt	Sets the interrupt.	IRQ5
1st DMA channel	Sets the DMA channel for playback.	DMA1
2nd DMA channel	Sets the DMA channel for recording.	DMA0
Security Menu		Default
User Password Is	Shows if a user password is set.	Clear
Administrator Password Is	Shows if an administrator password is set.	Clear
Set User Password	Press ENTER to set, change, or clear user password. Password length can be no longer than 8 characters, 0-9, A-Z.	
Set Administrator Password	Press ENTER to set, change, or clear administrator password. This password protects BIOS Setup settings.	
Boot	Sets whether a user password is required when the computer boots.	Enabled
Resume	If boot security is enabled, sets whether a user password is required when resuming from a suspended state.	Enabled
Undock	If boot security is enabled, sets whether a user password is required when undocking the OmniBook.	Disabled
Hard Disk Drive Lock	If boot security is enabled, sets whether a password is stored on the hard disk. Secures data on the disk if the disk is moved to another computer.	Disabled
Floppy Boot	Sets whether the floppy drive is a boot device.	Enabled
Power Menu		Default
Power Management Mode	Disables time-outs, selects a combination of time-outs, or allows customized time-outs.	Max Power Savings
Smart CPU Mode	Enables automatic CPU power savings. Absence of keyboard, mouse, and hard disk activity could cause slower CPU response.	Off
Standby Time-out	Sets the period of inactivity after which the computer goes from On to Standby power mode.	2 minutes
Suspend Time-out	Sets the period of inactivity after which the computer goes from Standby to Suspend power mode. (Skips Standby mode if that time-out is disabled.)	4 minutes
Hibernate Time-out	Sets whether the computer goes from Suspend to Hibernate power mode after the indicated period of inactivity. (Skips Suspend mode if that time-out is disabled.)	4 hours
Hard Disk Time-out	Sets the period of hard disk inactivity after which the hard disk stops spinning.	2 minutes

Time-out on AC	Sets whether power management time-outs occur while the ac adapter is connected.	Disabled
Power Button Mode	Sets the action of the blue power button when pressed for less than 4 seconds.	Suspend
Resume on Modem Ring	Sets whether the system resumes from Suspend if a ring signal is received.	Enabled
Resume on Time of Day	Sets whether the system resumes from Suspend at a defined time of day.	Disabled
Resume Time	Sets the 24-hour time when the system resumes from Suspend if enabled.	
Auto Suspend on Undock	Sets whether the OmniBook suspends after undocking.	When Lid Closed
Boot Menu		Default
Diskette Drive Hard Drive CD-ROM Drive	Shows the order of boot devices. Move the entries to change the order.	1. Diskette drive 2. Hard drive 3. CD-ROM drive
Exit Menu		
Save Changes and Exit	Saves Setup changes, exits, and reboots.	
Discard Changes and Exit	Discards Setup changes since last save, exits, and reboots. Does not affect Security and date/time changes.	
Get Default Values	Restores default settings, stays in Setup. Does not affect Security and date/time settings.	
Load Previous Values	Discards Setup changes since last save, stays in Setup. Does not affect Security and date/time changes.	
Save Changes	Saves Setup changes, and stays in Setup. Security settings are saved when changed.	

Replaceable Parts

This chapter contains an exploded view of the OmniBook and the following lists of parts:

- OmniBook replaceable parts (page 4-2).
- Assembly-component breakout (page 4-7)
- Accessory replacement parts (page 4-7).
- Part number reference (page 4-8).

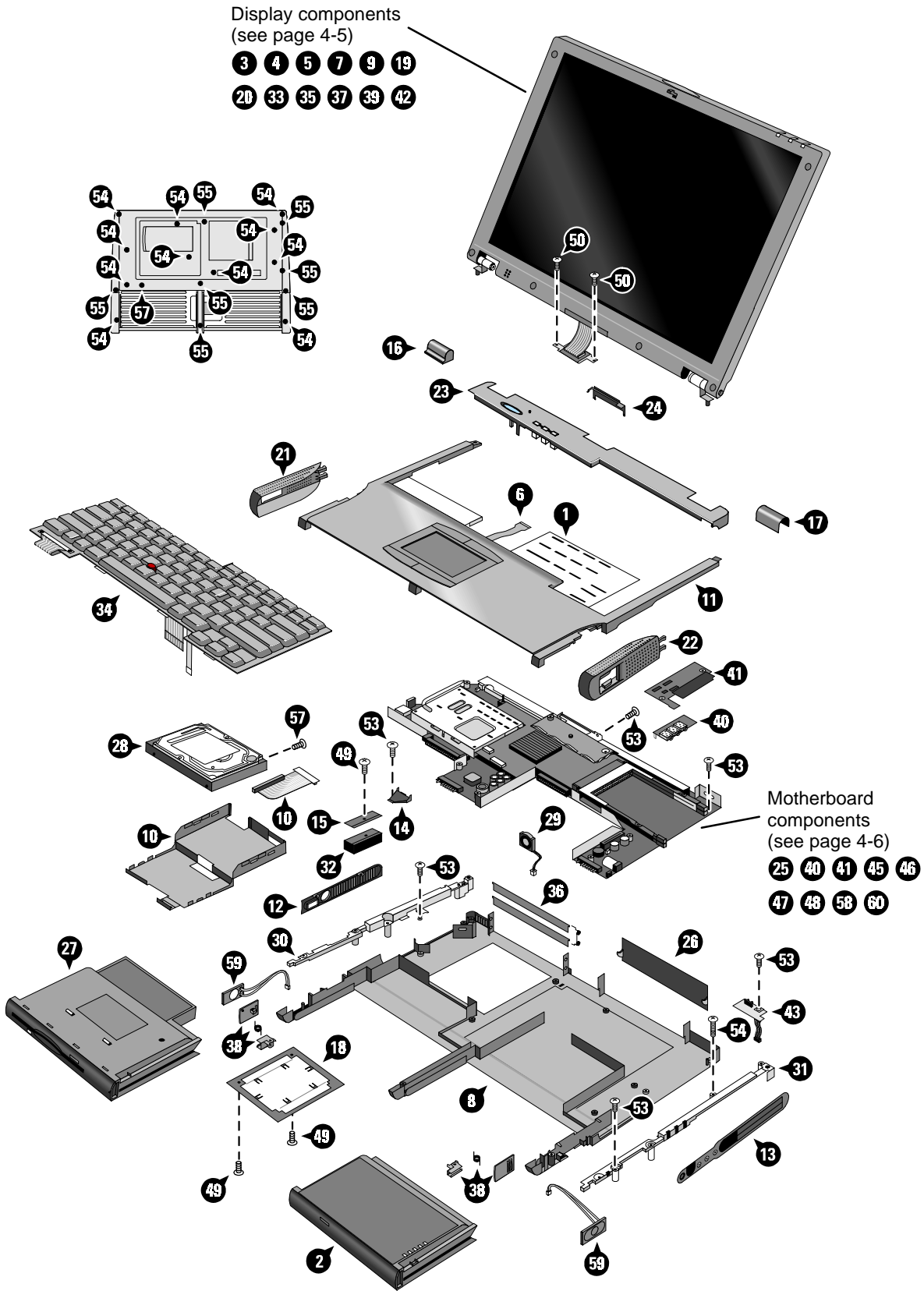

Figure 4-1. Exploded View

Table 4-1. OmniBook Replaceable Parts

	Description	Part Number	Exchange Part Number	User-Replaceable
1	Assembly, touch-pad support *	F1460-60947		
2	Battery, lithium-ion	F1466-80001		Yes
3	Bezel, display (LG 14")	F1460-60967		
3	Bezel, display (Samsung 13")	F1460-60969		
4	Cable, LCD flex (LG 14")	F1460-60981		
4	Cable, LCD flex (Samsung 13")	F1460-60975		
5	Cable, LED strip	F1460-60972		
6	Cable, touch-pad flex	F1460-60948		
7	Cap, end (display)			
	Cap, pointing stick	F1320-60971		Yes
8	Case, bottom *	F1460-60961		
9	Case, display (13") *	F1460-60970		
9	Case, display (14") *	F1460-60968		
10	Case, HDD kit	F1460-60982		
11	Case, top *	F1460-60946		
12	Cover, air vent (and PS/2, USB)	F1460-60956		
13	Cover, audio jack	F1460-60959		
14	Cover, heat exchange (fan)	F1460-60955		
15	Cover, heatsink	F1460-60952		
16	Cover, hinge (left)	F1460-60941		
17	Cover, hinge (right)	F1460-60940		
18	Cover, RAM/BIOS	F1460-80013		Yes
19	Cover, screw (lower, flat)			Yes
20	Cover, screw (upper, domed)			Yes
21	Cover, speaker (left) *	F1460-60945		
22	Cover, speaker (right) *	F1460-60944		
23	Cover, strip (top case)	F1460-60942		
24	Cover, VGA connector	F1460-60943		Yes
25	CPU module (MMO), 233MHz Pentium II (MD) *	1821-4303	F1440-69103	
25	CPU module (MMO), 266MHz Pentium (T) *	1821-4302	F1440-69102	
25	CPU module (MMO), 266MHz Pentium II (MD) *	1821-4304	F1440-69104	
26	Door, I/O	F1460-60965		Yes
27	Drive, floppy disk module (no cable)	F1472-80001		Yes
28	Drive, hard disk (4.0GB, IBM)	0950-2671	F1386-69100	
28	Drive, hard disk (4.0GB, Toshiba)	0950-2865	F1386-69101	
28	Drive, hard disk (6.4GB, IBM)	0950-2785	F1475-69100	
29	Fan	F1460-60954		
	Foot, rubber	F1460-60991		Yes
30	Frame, left	F1460-60957		
31	Frame, right	F1460-60958		
32	Heatsink (finned)	F1460-60953		
33	Hinges, display (left and right)	F1460-60973		
	IC, BIOS, Pentium II (MD)	F1460-12007		
	IC, BIOS, Pentium (T)	F1460-12016		
34	Keyboard, Danish	F1460-60932		
34	Keyboard, French	F1460-60923		
34	Keyboard, French-Canadian	F1460-60927		
34	Keyboard, German	F1460-60924		
34	Keyboard, International English	F1460-60922		
34	Keyboard, Italian	F1460-60926		
34	Keyboard, Norwegian	F1460-60930		

	Description	Part Number	Exchange Part Number	User-Replaceable
34	Keyboard, Spanish	F1460-60925		
34	Keyboard, Swedish	F1460-60929		
34	Keyboard, Swiss	F1460-60928		
34	Keyboard, UK English	F1460-60931		
34	Keyboard, US English	F1460-60921		
35	Kit, display case (latch, spring, cable holder/cover)	F1460-60971		
36	Kit, dock door (doors, springs)	F1460-60964		Yes
37	Kit, LCD (shield, brackets) (LG 14")	F1460-60980		
37	Kit, LCD (shield, brackets) (Samsung 13")	F1460-60974		
38	Kit, module latch (latches, sliders, springs)	F1460-60963		
	Label, regulatory/business card	F1460-60962		
39	LCD module (LG 14")	F1440-60995	F1440-69095	
39	LCD module (Samsung 13")	F1460-60998	F1460-69098	
	Module, filler	F1460-80015		Yes
	Overlay, serial number	7121-7525		
40	PCA, audio jack	F1460-60913		
41	PCA, DC-DC	F1460-60912		
42	PCA, inverter (LG 14")	F1460-60918		
42	PCA, inverter (Samsung 13")	F1460-60917		
43	PCA, IR	F1460-60911		
44	PCA, LVDS (LG 14")	F1460-60916		
44	PCA, LVDS (Samsung 13")	F1460-60914		
45	PCA, motherboard *	F1460-60902	F1460-69002	
46	PCA, VGA	F1460-60906		
47	Plate, CPU bottom	F1460-60949		
48	Plate, CPU top, Pentium (T)	F1460-60950		
48	Plate, CPU top, Pentium II (MD)	F1460-60951		
49	Screw, M2x3.5mm			
50	Screw, M2x4mm	F1460-60989		
51	Screw, M2x14mm	F1460-60988		
52	Screw, M2.5x4mm			
53	Screw, M2.5x5mm	F1460-60984		
54	Screw, M2.5x16mm	F1460-60986		
55	Screw, M2.5x19mm	F1460-60985		
56	Screw, M3x3mm	F1460-60983		
57	Screw, M3x4mm	F1460-60990		
58	Socket, PCMCIA	F1460-60919		
59	Speaker	F1460-60960		
60	Standoff, VGA			
	Thermal pads, Pentium (T)			
	Thermal pads, Pentium II (MD)			
*	See Table 4-2 for components.			

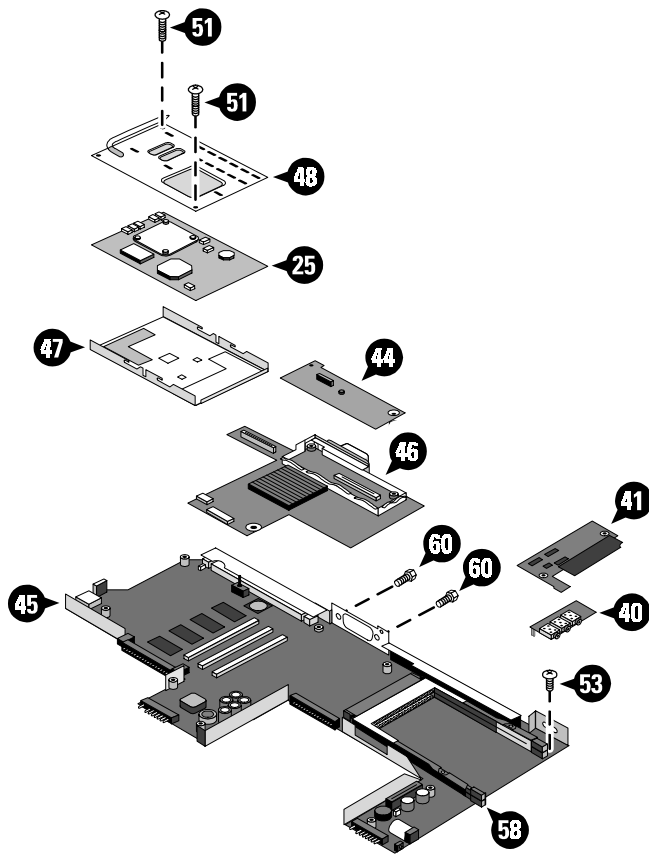

Figure 4-3. Motherboard Components

Table 4-2. Assembly-Component Breakdown

Assembly	Part Number	Exchange Part Number	Components	Part Number	Included in Assembly
Case, bottom	F1460-60961		Cover, RAM/BIOS	F1460-80013	No
			Docking doors	F1460-60964	No
			Feet (2)	F1460-60991	Yes
			I/O door	F1460-60965	No
			Label, regulatory/ business card	F1460-60962	No
			Overlay, serial number	7121-7525	No
			Module latches	F1460-60963	No
Case, display	F1460-60970 F1460-60968		Display kit (latch, cable holder)	F1460-60971	No
Case, top	F1460-60946		Touch-pad support assembly	F1460-60947	No
Cover, speaker	F1460-60945 F1460-60944		Foot (1)	F1460-60991	Yes
CPU module (MMO)	(all)	(all)	Thermal pads	(all)	No
PCA, motherboard	F1460-60902	F1460-69002	BIOS IC	F1460-12007	Yes
			PCMCIA socket	F1460-60919	Yes
Touch-pad support assembly	F1460-60947		Touch-pad flex cable	F1460-60948	Yes

Table 4-3. Accessory Replaceable Parts

Description	Part Number	Exchange Part Number	User-Replaceable
Adapter, ac (60W)	0950-2790		Yes
Adapter, auto plug (from airline)	5182-5131		Yes
Adapter, auto/airline (75W)	F1455-60001		Yes
Adapter, PS/2 "Y"	F1469-80001		Yes
Battery, lithium-ion	F1466-80001		Yes
Cable, external FDD	F1473-80001		Yes
Drive, CD-ROM module	F1474-80001		Yes
Drive, floppy disk module (no cable)	F1472-80001		Yes
Drive, LS-120 module	F1470-80001		Yes
Module, filler	F1460-80015		Yes
Monitor stand (short)	F1453-60901		Yes
RAM board, 32MB	1818-7413	F1456-69001	Yes
RAM board, 64MB	1818-7414	F1457-69001	Yes

Table 4-4. Part Number Reference

Part Number	Exchange Part Number	Description	User-Replaceable
		Cap, end (display)	
		Cover, screw (lower, flat)	Yes
		Cover, screw (upper, domed)	Yes
		Screw, M2x3.5mm	
		Screw, M3x4mm	
		Standoff, VGA	
		Thermal pads, Pentium (T)	
		Thermal pads, Pentium II (MD)	
0950-2671	F1386-69100	Drive, hard disk (4.0GB, IBM)	
0950-2785	F1475-69100	Drive, hard disk (6.4GB, IBM)	
0950-2790		Adapter, ac (60W)	Yes
0950-2865	F1386-69101	Drive, hard disk (4.0GB, Toshiba)	
1818-7413	F1456-69001	RAM board, 32MB	Yes
1818-7414	F1457-69001	RAM board, 64MB	Yes
1821-4302	F1440-69102	CPU module (MMO), 266MHz Pentium (T)	
1821-4303	F1440-69103	CPU module (MMO), 233MHz Pentium II (MD)	
1821-4304	F1440-69104	CPU module (MMO), 266MHz Pentium II (MD)	
5182-5131		Adapter, auto plug (from airline)	Yes
7121-7525		Overlay, serial number	
8120-6312		Power cord, replacement (Australia).	Yes
8120-6313		Power cord, replacement (U.S., Canada, Taiwan).	Yes
8120-6314		Power cord, replacement (Europe).	Yes
8120-6315		Power cord, replacement (Hong Kong, Singapore, U.K.).	Yes
8120-6316		Power cord, replacement (Japan).	Yes
8120-6317		Power cord, replacement (India, South Africa).	Yes
8120-8373		Power cord, replacement (People's Republic of China).	Yes
F1320-60971		Cap, pointing stick	Yes
F1440-60995	F1440-69095	LCD module (LG 14")	
F1453-60901		Monitor stand (short)	Yes
F1455-60001		Adapter, auto/airline (75W)	Yes
F1460-12007		IC, BIOS, Pentium II (MD)	
F1460-12016		IC, BIOS, Pentium (T)	
F1460-60902	F1460-69002	PCA, motherboard	
F1460-60906		PCA, VGA	
F1460-60911		PCA, IR	
F1460-60912		PCA, DC-DC	
F1460-60913		PCA, audio jack	
F1460-60914		PCA, LVDS (Samsung 13")	
F1460-60916		PCA, LVDS (LG 14")	
F1460-60917		PCA, inverter (Samsung 13")	
F1460-60918		PCA, inverter (LG 14")	
F1460-60919		Socket, PCMCIA	
F1460-60921		Keyboard, US English	
F1460-60922		Keyboard, International English	
F1460-60923		Keyboard, French	

Part Number	Exchange Part Number	Description	User-Replaceable
F1460-60924		Keyboard, German	
F1460-60925		Keyboard, Spanish	
F1460-60926		Keyboard, Italian	
F1460-60927		Keyboard, French-Canadian	
F1460-60928		Keyboard, Swiss	
F1460-60929		Keyboard, Swedish	
F1460-60930		Keyboard, Norwegian	
F1460-60931		Keyboard, UK English	
F1460-60932		Keyboard, Danish	
F1460-60940		Cover, hinge (right)	
F1460-60941		Cover, hinge (left)	
F1460-60942		Cover, strip (top case)	
F1460-60943		Cover, VGA connector	Yes
F1460-60944		Cover, speaker (right)	
F1460-60945		Cover, speaker (left)	
F1460-60946		Case, top	
F1460-60947		Assembly, touch-pad support	
F1460-60948		Cable, touch-pad flex	
F1460-60949		Plate, CPU bottom	
F1460-60950		Plate, CPU top, Pentium (T)	
F1460-60951		Plate, CPU top, Pentium II (MD)	
F1460-60952		Cover, heatsink	
F1460-60953		Heatsink (finned)	
F1460-60954		Fan	
F1460-60955		Cover, heat exchange (fan)	
F1460-60956		Cover, air vent (and PS/2, USB)	
F1460-60957		Frame, left	
F1460-60958		Frame, right	
F1460-60959		Cover, audio jack	
F1460-60960		Speaker	
F1460-60961		Case, bottom	
F1460-60962		Label, regulatory/business card	
F1460-60963		Kit, module latch (latches, sliders, springs)	
F1460-60964		Kit, dock door (doors, springs)	Yes
F1460-60965		Door, I/O	Yes
F1460-60967		Bezel, display (LG 14")	
F1460-60968		Case, display (14")	
F1460-60969		Bezel, display (Samsung 13")	
F1460-60970		Case, display (13")	
F1460-60971		Kit, display case (latch, spring, cable holder/cover)	
F1460-60972		Cable, LED strip	
F1460-60973		Hinges, display (left and right)	
F1460-60974		Kit, LCD (shield, brackets) (Samsung 13")	
F1460-60975		Cable, LCD flex (Samsung 13")	
F1460-60980		Kit, LCD (shield, brackets) (LG 14")	
F1460-60981		Cable, LCD flex (LG 14")	
F1460-60982		Case, HDD kit	

Part Number	Exchange Part Number	Description	User-Replaceable
F1460-60983		Screw, M3x3mm	
F1460-60984		Screw, M2.5x5mm	
F1460-60985		Screw, M2.5x19mm	
F1460-60986		Screw, M2.5x16mm	
F1460-60987		Screw, M2.5x5mm	
F1460-60988		Screw, M2x14mm	
F1460-60989		Screw, M2x4mm	
F1460-60990		Screw, M2.5x4mm	
F1460-60991		Foot, rubber	Yes
F1460-60998	F1460-69098	LCD module (Samsung 13")	
F1460-80013		Cover, RAM/BIOS	Yes
F1460-80015		Module, filler	Yes
F1460-90020		Service Manual (OB4100)	Yes
F1462-60901		OmniBook Performance 98 Group training kit	
F1462-60910		Recovery CD, English (OB4100, W95)	
F1462-60911		Recovery CD, German (OB4100, W95)	
F1462-60912		Recovery CD, French (OB4100, W95)	
F1462-60913		Recovery CD, Spanish (OB4100, W95)	
F1462-60914		Recovery CD, Italian (OB4100, W95)	
F1462-60915		Recovery CD, Swedish (OB4100, W95)	
F1462-60916		Recovery CD, English (OB4100, WNT)	
F1462-60917		Recovery CD, German (OB4100, WNT)	
F1462-60918		Recovery CD, French (OB4100, WNT)	
F1462-60919		Recovery CD, Spanish (OB4100, WNT)	
F1462-60920		Recovery CD, Italian (OB4100, WNT)	
F1462-60921		Recovery CD, Swedish (OB4100, WNT)	
F1466-80001		Battery, lithium-ion	Yes
F1469-80001		Adapter, PS/2 "Y"	Yes
F1470-80001		Drive, LS-120 module	Yes
F1472-80001		Drive, floppy disk module (no cable)	Yes
F1473-80001		Cable, external FDD	Yes
F1474-80001		Drive, CD-ROM module	Yes

Reference Information

This chapter includes the following reference information:

- Password removal policy.
- Display quality statement.

Password Removal Policy

If the user forgets the system password, the user calls Technical Support to determine the proper removal procedure. The user must provide proof of ownership, and the OmniBook must be operated during the procedure.

The password removal procedure is protected as HP Company Private information. There are a restricted number of locations that can perform password removal. It may not be disclosed or distributed outside those locations.

Password removal is strictly controlled. Hewlett-Packard and authorized support providers must ensure with written evidence that the OmniBook being “cleansed” is actually in the possession of the unit’s actual and current owner. This requires a sales receipt showing the unit serial number and owner’s name, or a written statement from the owner attesting that he or she is the owner of the unit. The statement can be a fax copy of the document. The fact that the unit is in the hands of an HP representative on behalf of the customer is not evidence of ownership. In addition, HP will not remove the password of a unit for any non-owner, even if it is requested by law enforcement agencies. If you receive such a request, you should notify management and HP Corporate Legal immediately. (These requests may require a court order prior to our participation.)

Further, the entity removing the password must log the name, serial number and date of the removal, and file the written backup with the log. The log and backup are subject to standard record retention process and review.

The final issue relating to removal of passwords is that HP cannot provide information to users that would assist them in improperly removing a password and opening a unit.

Hewlett-Packard Display Quality Statement

TFT display manufacturing is a high precision but imperfect technology and manufacturers cannot currently produce large displays that are cosmetically perfect. Most, if not all, TFT displays will exhibit some level of cosmetic imperfection. These cosmetic imperfections may be visible to the customer under varying display conditions and can appear as bright, dim, or dark spots. *This issue is common across all vendors supplying TFT displays in their products and is not specific to the HP OmniBook display.*

HP OmniBook TFT displays meet or exceed all TFT manufacturer's standards for cosmetic quality of TFT displays. HP does not warrant that the displays will be free of cosmetic imperfections. *TFT displays may have a small number of cosmetic imperfections and still conform to the display manufacturer's cosmetic quality specifications.*

Here are some guidelines to use in determining what action to take on customers' complaints of cosmetic imperfections in their TFT displays:

1. The unit should be viewed in the customer's normal operating condition.

This means if the customer uses the unit predominately in DOS, in Windows, or in some other application or combination of applications, that is where you should make the determination. Self test is not a normal operating condition and is not a sufficient tool to interpret display quality.

2. Use the table below to determine whether the display should be considered for replacement.

These are the only conditions in this guideline that may call for a replacement due to a defect in material or workmanship based on the HP Limited Warranty Statement.

3. If a display is considered for replacement, it should be clear to the customer that cosmetic variations on the replacement display may also exist, and may require the customer to use a work-around to obscure the cosmetic imperfection.
4. Customers with cosmetic-based complaints only, that do not conform to the above conditions and tests will not normally be considered for display replacement. It will be left to the judgment of the HP-responsible person working with the customer, to identify work-arounds that are reasonable and appropriate for the individual customer. Customers who must have a more perfect display solution should consider switching to an OmniBook with a DSTN display.

We expect over time that the industry will continue to improve in its ability to produce displays with fewer inherent cosmetic imperfections, and we will adjust our HP guidelines as the improvements are implemented.

Table 5-1. OmniBook 4100 LCD Guidelines (TFT)

Type of Imperfection	Imperfections Not Allowed
LG 14" TFT, XGA	
Electrical Imperfections: Bright dots (a) Dark dots (a)	<ul style="list-style-type: none"> • 7 or more single bright dots. • 7 or more single dark dots. • 3 or more double bright dots. • 3 or more double dark dots. • 11 or more total bright and dark dot imperfections. • Any occurrence of triple bright dots (or triple dark dots). • Any occurrence of 3 bright dots within 20 mm (or 3 dark dots).
Mechanical Imperfections: Spots (b) Lines (c) Polarizer scratches (d) Polarizer dents, bubbles (e)	<ul style="list-style-type: none"> • 6 or more spots 0.2-0.5 mm avg. dia. • 4 or more lines 0.3-3 mm long and over 0.07 mm wide. • 5 or more scratches 5-20 mm long and over 0.02 mm wide. • 9 or more dents or bubbles 0-0.5 mm avg. dia. • Any spot over 0.5 mm avg. dia. • Any line over 3 mm long or 0.1 mm wide. • Any scratch over 20 mm long or 0.05 mm wide. • Any dent or bubble over 0.5 mm avg. dia.
Samsung 13" TFT, XGA	
Electrical Imperfections: Bright dots (a) Dark dots (a)	<ul style="list-style-type: none"> • 11 or more single bright dots. • 11 or more single dark dots. • 2 or more double bright dots. • 6 or more double or triple dark dots. • 21 or more total bright or dark dot imperfections. • Any occurrence of 2 single/double bright dots within 15 mm. • Any occurrence of 2 single/double/triple dark dots within 5 mm.
Mechanical Imperfections: Spots (b) Lines (c) Polarizer scratches (d) Polarizer dents, bubbles (e)	<ul style="list-style-type: none"> • 5 or more spots 0.1-0.5 mm avg. dia. • 5 or more lines 0.3-1 mm long and over 0.01 mm wide. • 4 or more scratches 0.3-10 mm long and over 0.01 mm wide. • 7 or more dents or bubbles 0-0.5 mm avg. dia. • Any spot over 0.5 mm avg. dia. • Any line over 1 mm long or 0.8 mm wide. • Any scratch over 10 mm long or 0.1 mm wide. • Any dent or bubble over 0.5 mm avg. dia.
Definitions of imperfections: a Bright or dark dot: A subpixel (red, green, or blue dot) that is stuck on or off. b Spot: A point on the display that appears dark or bright and does not change in size. Caused by foreign circular matter on the backlight. c Line: A line on the display that appears dark or light and does not change in size. Caused by contamination (lint, hair) behind the display. d Polarizer scratch: A light line that is visible on a darker background and does not change in size. e Polarizer dent or bubble: A light spot with a darker border that appears on a lighted display and does not change in size.	

- 1. Product Information**
- 2. Removal and Replacement**
- 3. Troubleshooting and Diagnostics**
- 4. Replaceable Parts**
- 5. Reference Information**