

**CM-5 COLOR MONITOR**  
**SHEET #2 (250-1023)**  
**FAXBACK DOC # 10377**

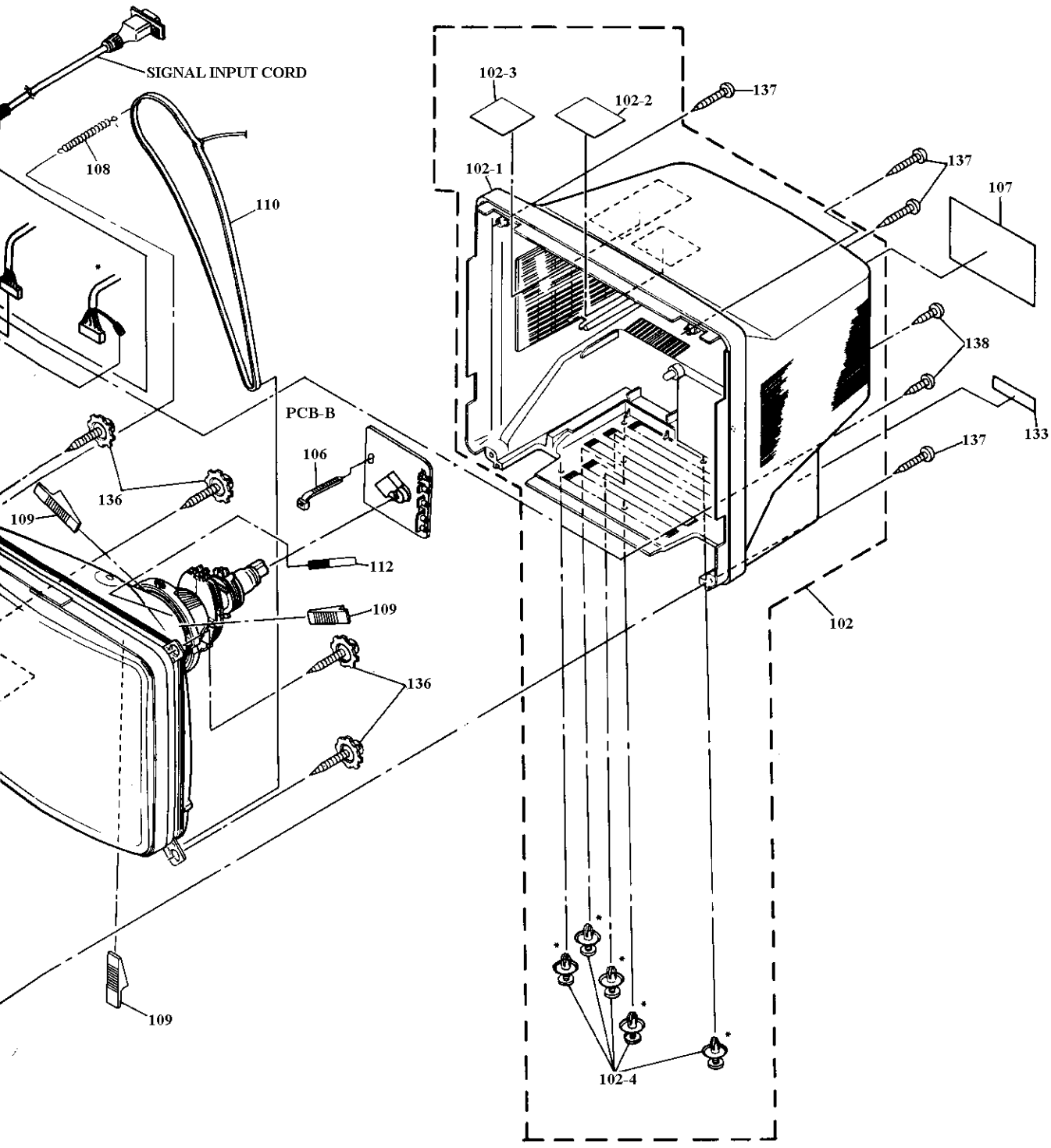

**CONTINUED ON**  
**SHEET # 1**