

# 15" COLOUR DISPLAY UNIT - CDU 1562/SA11

This unit is manufactured by **SALORA** and bears the marking **CDU 1562/SA11** on the rear and **DSM 27-615** on the Progetto di Gestione.

It can display all resolutions offer by Olivetti standard until 1024 x 768 75 Hz.

## CHARACTERISTICS

Ergonomic, multiscan, low emission, VGA-compatible, analog video.

- Screen dimensions: 15"  
Horizontal dimension: 262 mm  $\pm$  3 mm  
Vertical dimension: 196 mm  $\pm$  3 mm
  - Input voltage: 110 V - 240 V  $\pm$  15%  
Mains frequency: 50 - 60 Hz  
Degauss: On powering up
  - Horizontal Synchronism:  
Frequency: 31.469 KHz (VGA standard mode)  
37,86 KHz (VGA ergo mode)  
48,077 KHz (Super VGA mode)  
48,363 KHz (VGA plus mode)  
58,14 KHz (VGA plus mode)  
Polarity: Negative or positive  
Level: TTL
  - Vertical Synchronism:  
Frequency: 59,95 - 70,08 Hz (VGA standard mode)  
72,8 Hz (VGA ergo mode)  
72,190 Hz (Super VGA mode)  
60,08 - 72,13 (VGA plus mode)  
Polarity: Negative or positive  
Level: TTL
  - Input signals:  
Video: R, G, B (Red, Green, Blue) driving  
Signal: Linear voltage steps (63 steps of 11 mV)  
Level: 0 - 700 mV  
Polarity: 75 ohm positive
  - Resolutions displayed: 640 x 350 rows x columns (VGA standard mode)  
640 x 400 rows x columns (VGA standard mode)  
640 x 480 rows x columns (VGA standard mode)  
640 x 480 rows x columns (VGA ergo mode)  
800 x 600 rows x columns (Super VGA mode)  
1024 x 768 rows x columns (VGA plus mode 60/70 Hz)
- NOTE:** The above resolution are preset by the manufacturer. Up to a further 14 resolution, can be selected by the user, providing that they are included in the range:  
31 KHz - 62 KHz Horizontal frequency  
48 Hz - 100 Hz Vertical frequency
- External Controls: Brightness - Contrast - Height - Width  
Vertical centering - Horizontal centering  
East-west correction

## DISASSEMBLING THE VIDEO COVER

1. Remove the power cable from the connectors on the back of the monitor.
2. Remove the two tabs on the top of the video cover.

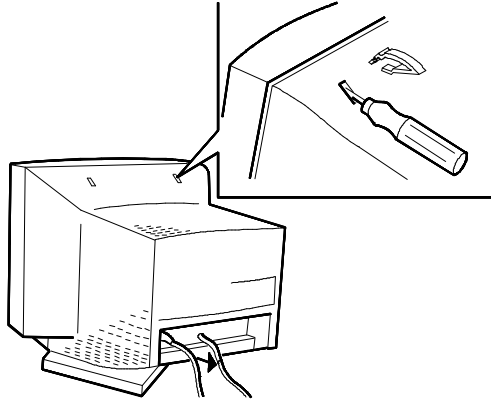

Fig. 21-1 Disassembling the Video Cover

---

3. Place the CRT screen on a flat surface (after placing sheets of paper on the workbench to prevent scratching of the glass).
4. Unscrew the two screws on the bottom part of the video cover.

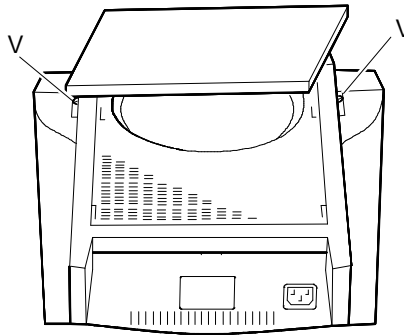

Fig. 21-2 Disassembling the Video Cover

---

5. Insert the special tools in the holes as indicated in the following figure.

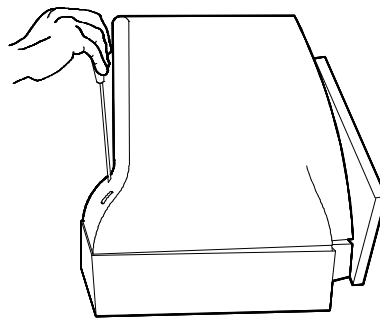

Fig. 21-3 Insertion of the Special Tools

---

6. Push to bottom these tools and remove the cover.

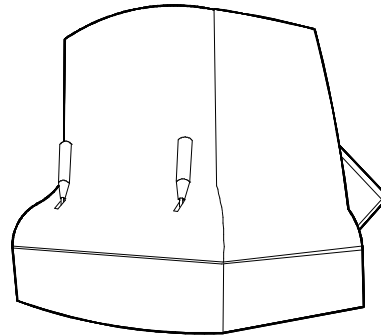

Fig. 21-4 Disassembling the Video Cover

### DISASSEMBLING THE VIDEO AMPLIFIER BOARD

7. Remove the white silicon adhesive binding the grids of the CRT to the connector on the video amplifier board (this is a transport precaution).
8. Remove the video amplifier board from the CRT connector.

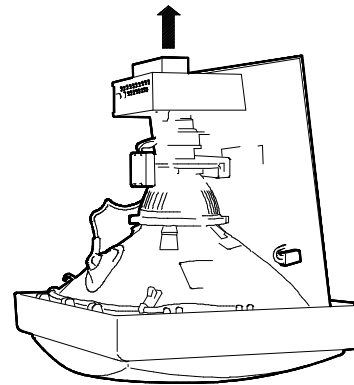

Fig. 21-5 Disassembling the Video Amplifier Board

9. To separate the video amplifier board from the metal support plate proceed as follows:
  - Remove the grounded faston connector attached to the metal plate of the monitor.
  - Desolder the metal support plate in the points (A) indicates in figure.

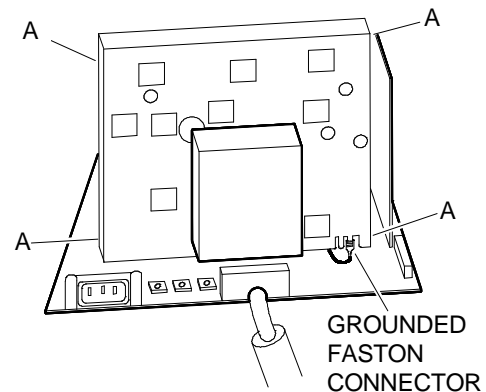

Fig. 21-6 Removing the Support Metal Plate

10. To separate the video amplifier board from the main board, proceed as follows:

- Remove connectors Q1 and Q2 of the video amplifier board.
- Desolder the white (FOCUS) cable from the CRT interface connector, the red (SCREEN) cable from connector G2 and the violet cable from the CRT.

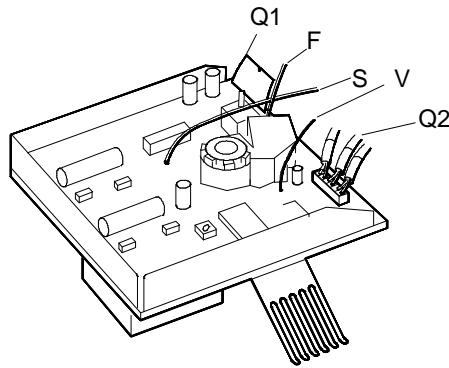

Fig. 21-7 Removing the Video Amplifier Board

### DISASSEMBLING THE MAIN BOARD

1. Disconnect Q13 degauss connector and Q3 deflection yoke connector.

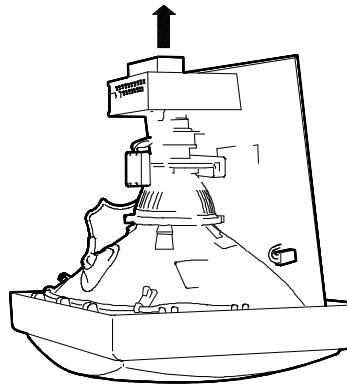

Fig. 21-8 Disassembling the Main Board

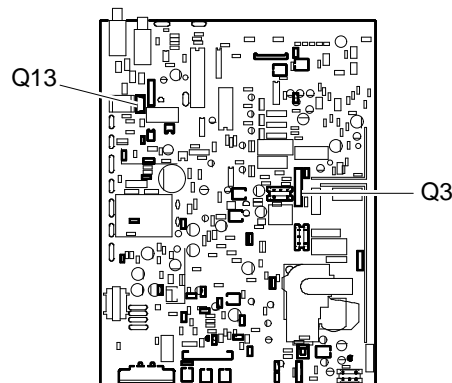

Fig. 21-9 Location of Q3 and Q13 Connectors

2. Before to disconnect the CRT anode from the EHV transformer (suction cup on the top of the CRT), check the discharge of the anode. To discharge anode, use a screwdriver, connecting it with a wire conductor to the monitor chassis ground. Put the end of the screwdriver under the rubber suction cup of the anode until it touches the two contacts of the CRT anode. Hold the screwdriver in contact with the anode for a few seconds until the high voltage is discharged.

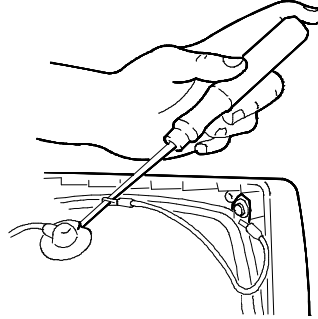

Fig. 21-10 Discharge of the CRT Anode

3. Remove the main board taking out in the direction indicated by the arrow.

**NOTE:** When you are reassembling the main board, be careful to insert the console regulation knobs in their holes, to avoid damaging them.

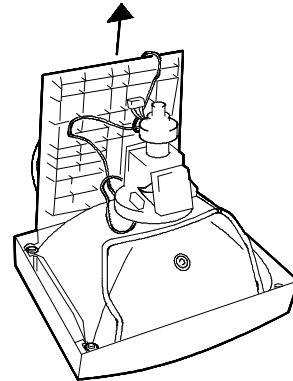

Fig. 21-11 Removing the Main Board

4. When replacing the main board, check that the metal ring, C, on the contacts of the EHV connection to the CRT anode is seated securely under the retaining ring, D, of the rubber suction cup, as shown in figure. This ensures a good contacts for the anode connection.

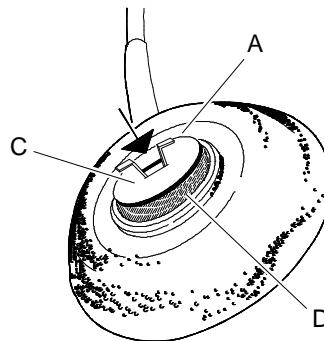

Fig. 21-12 Replacement of the Metal Ring

## DISASSEMBLING THE CRT

**NOTE:** The CRT forms a single assembly with the yoke, on which are mounted deflection coils and convergence magnets. The magnets are factory set for the tube on which they are mounted and should not be re-adjusted, as this will result in mis-convergence, which is difficult to correct. A replacement tube is supplied with the yoke already mounted.

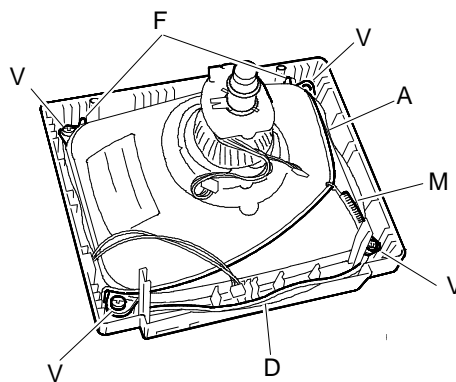

Fig. 21-13 Disassembling the CRT

5. Unscrew the four screws A fixing the CRT to the front cover.
6. Cut the two bands holding the degauss coil.
7. Lift the CRT from the front cover, freeing the degauss winding.
8. Remove the catching braid from the CRT by unhoking the earthing braid tensioning spring. The earthing braid should be fixed to the replacement tube.

## VIDEO ADJUSTMENTS

Two types of video adjustment are available:

User Mode

Service Mode.

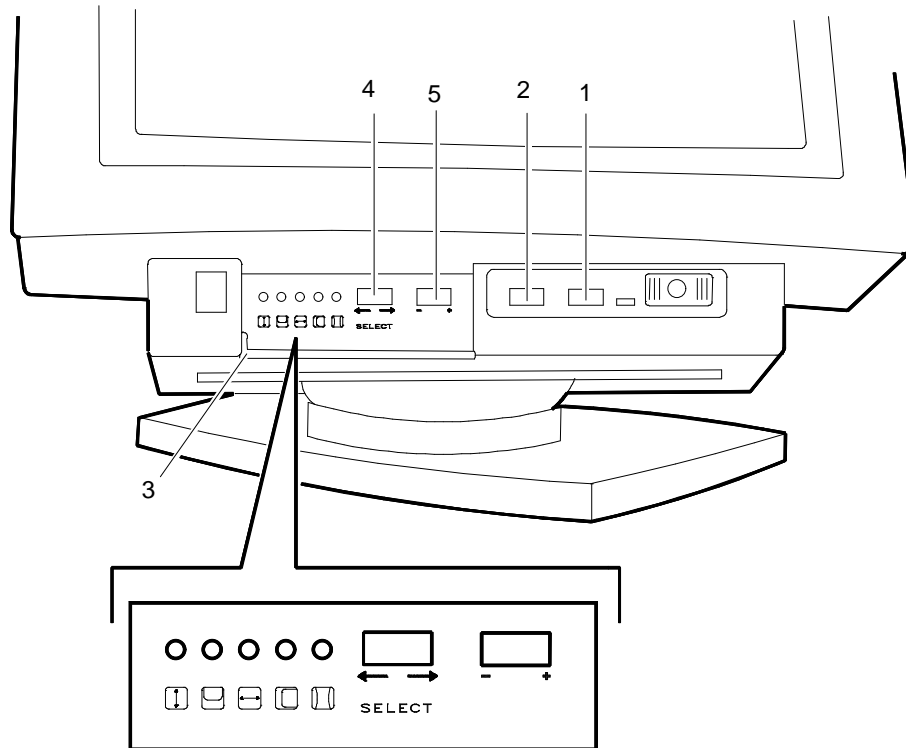

Fig. 21-14 Regulation Switches Position

### USER MODE

#### Contrast

Select the proper contrast (1) with the rocker switch. Adjust the contrast adequately according to the ambient light to obtain best picture quality. Excessive contrast causes eye strain.

#### Brightness

Adjust the brightness (2) with the rocker switch according to the ambient light.

#### Picture geometry, placement

The adjustment switches are located under the panel (3). Select the property to be adjusted with the rocker switch (4). The symbol of the selected adjustment is indicated with light.

Adjust each property with the rocker switch +/- (5); adjustments are stored automatically.

The following picture properties are adjustable:

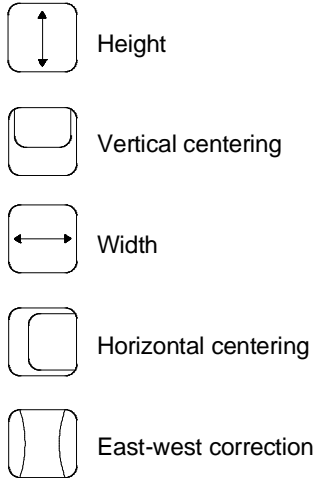

**Convergence**

All colours on the screen are generated with three electron beams called red (R), green (G) and blue (B) beam. If the beams do not completely match with each others, the result is convergence error. Convergence error may be disturbing with certain colours and may cause a stereoscopic effect.

Normally there is no need to change the factory preset convergence adjustments.

**RETURNING TO THE FACTORY ADJUSTMENTS**

For returning to the factory preset adjustments, deleting all user made settings proceed as follows:

Switch the monitor off.

Press simultaneously ← (4) and – (5) switches and release them 5 seconds after the monitor is switched on.

**SERVICE MODE**

Most of the adjustments are performed with user keys in service mode. The values are stored in non volatile memory of the monitor.

**Access to the Service Mode**

Switch the monitor off with power switch.

While keeping → down (1) switch the monitor on with power switch (2).

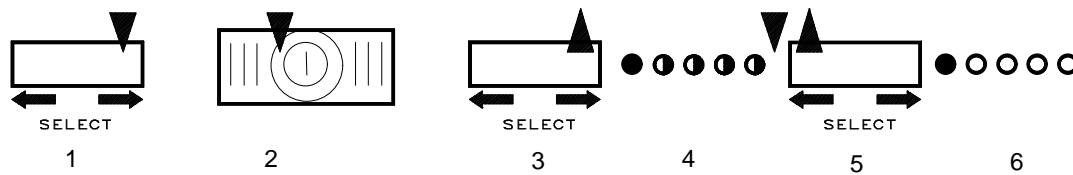

Fig. 21-15 Access to the Service Mode



Release → (3) after 1 second. Four LEDs (4) start blinking.

Push ← (5) within 5 seconds. Four LEDs (6) remains on.

**NOTE:** During one second period in startup the operation of the LEDs is not specified.

The monitor is now on the first step of the adjustment sequence of 6 steps.

The adjustments can be scanned up and down with → and ←. Adjustments are performed with +/- key on each step.

### Preliminary Preparations

Select crosshatch test pattern (1024 x 768 pixel 61.4 KHz/75 Hz).

Set contrast and brightness to maximum.

Adjust G2 voltage with **RT8** until the background raster is faintly visible (use **SCREEN** adjustment, if **RT8** is not enough).

Adjust the sharpness with **FOCUS** to optimum.

Connect high voltage meter to the anode of the picture tube and adjust the high voltage to  $25 \pm 0.2$  KV with **RT9** (see figure 4-4).

### Adjustment Procedure

The order of adjustments explained here has been found to produce the desired result with the minimum of effort.

Adjustments can also be made in another order or completely separately.

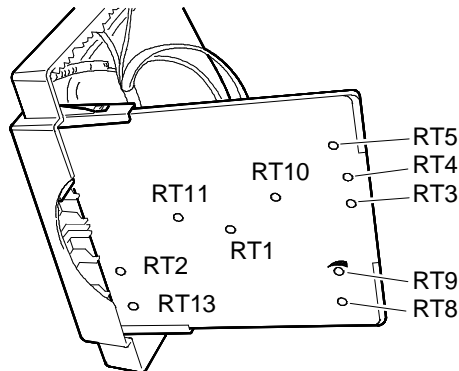

Fig. 21-16 Main Board Potentiometers Location

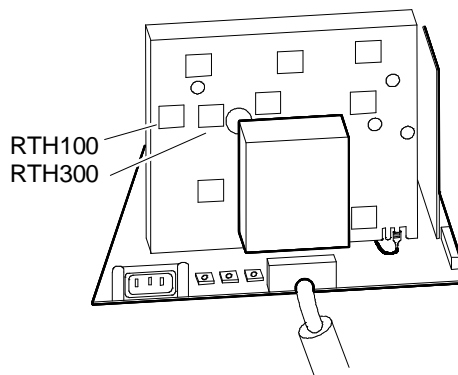



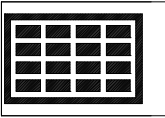
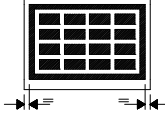

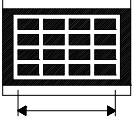

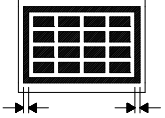

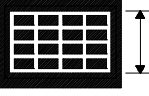

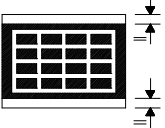

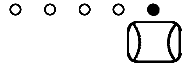
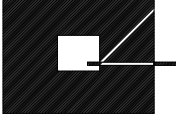
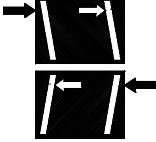



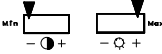





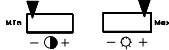

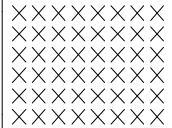

Fig. 21-17 Video Amplifier Board Potentiometers Location

Step	Adjustment/Display 	Adj. key or trimmer	Effect (adjustments are stored automatically)	Conditions 
1	Width 		Reduces width until both vertical edges of the picture are visible. 	
2		RT11	Center the raster to the mask. 	
3			Adjust width: 262 ± 2 mm. 	
4	Horizontal centering 		Center the picture. 	
5	Height 		Adjust the height: 192 ± 2 mm. 	
6	Vertical centering 		Center the picture vertically to the mask. 	

Step	Adjustment/Display 	Adj. key or trimmer	Effect (adjustments are stored automatically)	Conditions 
7	East/West correction 	RT13	Adjust vertical lines upright. 	
8		RT12	Adjust vertical lines upright. 	
9		RT1	Adjust vertical lines symmetrically with respect to centerline. 	
10			Adjust vertical lines upright. 	
3, 4, 5, 6, 10			Repeat these steps for each timing to be adjusted.	
11	S-capacitor selection 		Push → to leave Service Mode. <b>Do not make any adjustments on this step.</b>	

Step	Adjustment	Adj. key or trimmer	Effect (adjustments are stored automatically)	Conditions 
1	Low light	RT3 RT4 RT5	Adjust black level trimmers for darkest picture (minimum). 	
2		RT8 (and SCREEN if necessary)	Adjust G2 voltage until the background is faintly visible. The most sensitive color has been marked in a label on the tubes graphite. It may not be correct if tube or video amplifier board has been changed. In that case judge the most sensitive color from the tone of the picture.  <b>Tone   Most sensitive color   Adjustment</b> Reddish   Red   RTA3 Greenish   Green   RTA4 Bluish   Blue   RTA5	
3		RT3 RT4 RT5	Adjust the picture visually grey. Do not adjust trimmer corresponding to the most sensitive color.	
4		RT8 (and SCREEN if necessary)	Place the probe of the color analyzer in the middle of the screen. Adjust picture brightness to 5 nits.	
5		RT3 RT4 RT5	Adjust for color coordinates in the window. Do not adjust trimmer corresponding to the most sensitive color.	
6			Adjust picture for brightness to 2 nits.	
7	High light		Adjust window bightness to 5o nits. 	
8		RTH100 RTH300	Adjust for color coordinates in the window.	

Step	Adjustment	Adj. key or trimmer	Effect (adjustments are stored automatically)	Conditions
9	Maximum contrast 	RT10	Adjust window to $200 \pm 10$ nits. 	
10	Focus  	FOCUS	Adjust sharpness of the lines to optimum. Lock SCREEN and FOCUS potentiometers. 	

### Storing and returning to the User Mode

Exit from Service Mode by pushing → on the last step (10) in the sequence. At the same time the adjusted values are stored to the memory for factory settings,. The monitor turns to normal user mode. If you want to leave the service mode without memorizing, switch off the monitor in service mode.

### USE OF THE MEMORY FOR PICTURE ADJUSTMENTS

Part of the picture adjustment values are stored in memory ICA19. The memory has separated areas for User Adjustments and for Factory Adjustments.

#### USER ADJUSTMENTS

If there are values available in the memory for user adjustments, corresponding to the present timing signals, they are always used.

User memory can be updated in normal User Mode with user controls. User memory contains 14 locations for freely programmable timings.

#### FACTORY ADJUSTMENTS

If the memory location mentioned in case 1 is empty, the picture adjustment values are read from memory for factory adjustments.

Factory adjustments, corresponding to the current timings, are transferred to user memory if any value is adjusted. After that the operation is as in case 1.

Factory adjustments can be updated in Service Mode with user controls. If there is no location for timings currently in use, the adjustment affects to the memory for user adjustments. The memory for factory adjustments contains 21 locations.

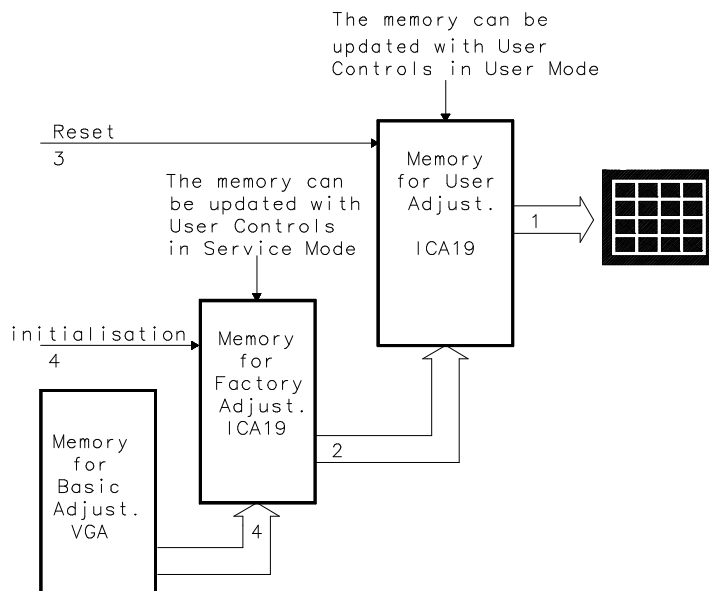

Fig. 21-18 Management of the Memory

**RESETTING THE USER MEMORY**

User memory can be emptied from all user settings including the timing information. Note that resetting deletes all data in any memory location.

Switch the monitor off.

Press simultaneously ← and – switches (1).

Switch the monitor on (2).

Wait 5 seconds and release the keys (3).

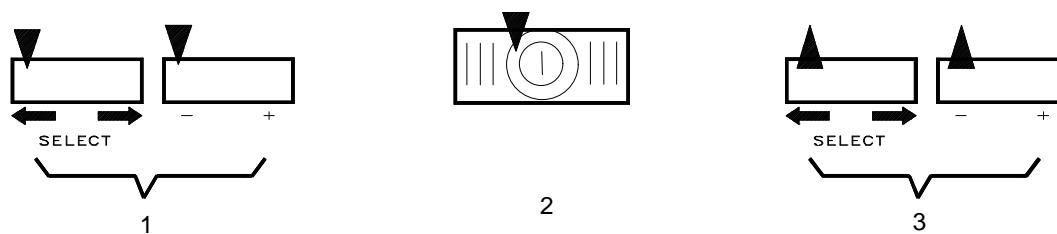

Fig. 21-19 Resetting the User Memory

The memory initialization takes place automatically.

